

Operating Instructions

Maintenance Guide 2

-
- 1 Paper and Other Media
 - 2 Troubleshooting

For safety, please read this manual carefully before you use this product and keep it handy for future reference.

Introduction

To get maximum versatility from this machine all operators should carefully read and follow the instructions in this manual. Please keep this manual in a handy place near the machine.

Please read the Safety Information in Maintenance Guide 1 before using this machine. It contains important information related to USER SAFETY and PREVENTING EQUIPMENT PROBLEMS.

Important

Contents of this manual are subject to change without prior notice. In no event will the company be liable for direct, indirect, special, incidental, or consequential damages as a result of handling or operating the machine.

Caution:

Use of controls or adjustment or performance of procedures other than those specified in this manual might result in hazardous radiation exposure.

Do not attempt any maintenance or troubleshooting other than that mentioned in this manual. This printer contains a laser beam generator and direct exposure to laser beams can cause permanent eye damage.

Notes:

Some illustrations in this manual might be slightly different from the machine.

Certain options might not be available in some countries. For details, please contact your local dealer.

Two kinds of size notation are employed in this manual. With this machine refer to the inch version.

For good print quality, the supplier recommends that you use genuine toner from the supplier.

The supplier shall not be responsible for any damage or expense that might result from the use of parts other than genuine parts from the supplier with your office products.

Trademarks

Microsoft, Windows and Windows NT are registered trademarks of Microsoft Corporation in the United States and/or other countries.

PostScript is a registered trademark of Adobe Systems Incorporated.

PCL is a registered trademark of Hewlett-Packard Company.

IPS-PRINT Printer Language Emulation Copyright© 1999-2000 Oak Technology, Inc., All rights reserved.

Ethernet is a registered trademark of Xerox Corporation.

Other product names used herein are for identification purposes only and might be trademarks of their respective companies. We disclaim any and all rights in those marks.

The proper names of the Windows operating systems are as follows:

- Microsoft® Windows® 95 operating system
- Microsoft® Windows® 98 operating system
- Microsoft® Windows® Millennium Edition (Windows Me)
- Microsoft® Windows® 2000 Professional
- Microsoft® Windows® 2000 Server
- Microsoft® Windows® XP Professional
- Microsoft® Windows® XP Home Edition
- Microsoft® Windows NT® Server operating system Version 4.0
- Microsoft® Windows NT® Workstation operating system Version 4.0

How to Read This Manual

Symbols

In this manual, the following symbols are used:

 **WARNING:**

This symbol indicates a potentially hazardous situation which, if instructions are not followed, could result in death or serious injury.

 **CAUTION:**

This symbol indicates a potentially hazardous situation which, if instructions are not followed, may result in minor or moderate injury or damage to property.

* The statements above are notes for your safety.

 **Important**

If this instruction is not followed, paper might be misfed, or data might be lost. Be sure to read this.

 **Preparation**

This symbol indicates the prior knowledge or preparations required before operating.

 **Note**

This symbol indicates precautions for operation, or actions to take after misoperation.

 **Limitation**

This symbol indicates numerical limits, functions that cannot be used together, or conditions in which a particular function cannot be used.

 **Reference**

This symbol indicates a reference.

[]

Keys that appear on the machine's panel display.

Keys and buttons that appear on the computer's display.

[]

Keys built into the machine's control panel.

Keys on the computer's keyboard.

TABLE OF CONTENTS

1. Paper and Other Media

Paper and Other Media Supported by This Printer	1
Paper Sizes.....	1
Paper Recommendations.....	7
Loading Paper	12
Loading Paper in Tray 1	12
Loading Paper in the Optional Paper Feed Unit	18
Loading Paper in the Bypass Tray	23

2. Troubleshooting

Error & Status Messages on the Control Panel	27
Printer Does Not Print	39
Other Printing Problems	42
Removing Misfed Paper	52
When "Remove Misfeed A: Internal Path" Appears	52
When "Remove Misfeed B: Fusing Unit" Appears	54
When "Remove Misfeed R: Finisher" Appears	56
When "Remove Misfeed Y: Paper Tray" Appears.....	57
When "Remove Misfeed Z: Duplex Unit " Appears	57
When "Remove Misfeed W: Mailbox" Appears	58
Removing Misfed Paper from the Interchange Unit	59
Removing Jammed Staples	61
Adding Staples	62
INDEX	64

1. Paper and Other Media



Paper and Other Media Supported by This Printer

Paper Sizes

This section describes the paper size, feed direction, and the maximum amount of paper that can be loaded into each paper tray in this printer.











Note

- The following symbols and terminology are used to represent the feed direction.

In this manual	On the panel display	Paper feed direction
 ← (Feed direction)	A4 (210 × 297) 8 1/2 × 11	Short-edge feed direction
 ← (Feed direction)	A4 (297 × 210) 11 × 8 1/2	Long-edge feed direction

- Be careful of the paper feed direction. The direction is determined for each paper size.

❖ Input Paper Sizes (Metric version)

	Feed direction	Size (mm)	Bypass Tray	Tray 1	Paper Feed Unit (Tray 2/3)
A3		297 × 420	☆	⊙	⊙
B4 JIS		257 × 364	☆	⊙	⊙
A4		210 × 297	☆	⊙	⊙
		297 × 210	☆	⊙	⊙
B5 JIS		182 × 257	☆	⊙	☆
		257 × 182	☆	⊙	⊙
A5		148 × 210	☆	☆	☆
		210 × 148	☆	⊙	⊙
B6 JIS		128 × 182	★	★	×
A6		105 × 148	☆	☆	×

	Feed direction	Size (mm)	Bypass Tray	Tray 1	Paper Feed Unit (Tray 2/3)
11 × 17 inches	☐	279 × 432	☆	☆	◎
Legal (LG, 8 ¹ / ₂ × 14 inches)	☐	216 × 356	☆	☆	☆
Letter (LT, 8 ¹ / ₂ × 11 inches)	☐	216 × 279	☆	◎	☆
	☐	279 × 216	☆	☆	◎
5 ¹ / ₂ × 8 ¹ / ₂ inches	☐	140 × 216	☆	☆	×
	☐	216 × 140	×	☆	☆
Executive (Exec., 7 ¹ / ₄ × 10 ¹ / ₂ inches)	☐	184 × 276	☆	☆	☆
	☐	276 × 184	☆	☆	×
Folio (8 ¹ / ₄ × 13 inches)	☐	210 × 330	☆	☆	☆
Foolscap (F4, 8 ¹ / ₂ × 13 inches)	☐	216 × 330	☆	☆	☆
F/GL (8 × 13 inches)	☐	203 × 330	☆	☆	☆
Com#10 Env (9 ¹ / ₂ × 4 ¹ / ₈ inches)	☐	241.3 × 104.8	☆	×	×
C5 Env (9.02 × 6.38 inches)	☐	229 × 162	☆	×	×
C6 Env (6.38 × 4.49 inches)	☐	162 × 114	☆	×	×
DL Env (8.66 × 4.33 inches)	☐	220 × 110	☆	×	×
Monarch Env (7 ¹ / ₂ × 3 ⁷ / ₈ inches)	☐	190.5 × 98.4	☆	×	×
Custom Size	-	-	★*	★	×
8K (10 ¹ / ₂ × 15.35 inches)	☐	267 × 390	☆	☆	☆
16K (7.68 × 10 ¹ / ₂ inches)	☐	195 × 267	☆	☆	☆
	☐	267 × 195	☆	☆	☆

- ◎ means that the size is supported and the printer selects the paper size automatically.
- ☆ means that the size is supported but the paper size should be selected with the control panel.
- ★ means that the size is supported but the paper size should be set with the control panel as a custom size. The supported size is approximately 100 - 297 mm in width and 148 - 432 mm in length. The supported size may differ depending on the printer language you use.
- ★* means that the supported size is approximately 90 - 305 mm in width and 148 - 457 mm in length. The supported size may differ depending on the printer language you use. Make the custom size setting with the control panel.
- × means that the size is not supported.

◆ Input Paper Sizes (Inch version)

	Feed direction	Size (inch)	Bypass Tray	Tray 1	Paper Feed Unit (Tray 2/3)
11 × 17 inches	☞	11 × 17	☆	◎	◎
Legal (LG, 8 1/2 × 14 inches)	☞	8 1/2 × 14	☆	◎	◎
Letter (LT, 8 1/2 × 11 inches)	☞	8 1/2 × 11	☆	◎	◎
	☞	11 × 8 1/2	☆	◎	◎
5 1/2 × 8 1/2 inches	☞	5 1/2 × 8 1/2	☆	☆	×
	☞	8 1/2 × 5 1/2	×	☆	◎
Executive (Exec.)	☞	7 1/4 × 10 1/2	☆	☆	☆
	☞	10 1/2 × 7 1/4	☆	☆	×
A3	☞	11.69 × 16.54	☆	☆	◎
B4 JIS	☞	10.12 × 14.33	☆	☆	☆
A4	☞	8.26 × 5.83	☆	◎	☆
	☞	5.83 × 8.26	☆	☆	◎
B5 JIS	☞	7.17 × 10.12	☆	◎	☆
	☞	10.12 × 7.17	☆	◎	◎
A5	☞	5.83 × 8.26	☆	☆	☆
	☞	8.26 × 5.83	☆	☆	☆
B6 JIS	☞	5.04 × 7.17	★	★	×
A6	☞	4.13 × 5.63	☆	☆	×
Folio	☞	8 1/4 × 13	☆	☆	☆
Foolscap F4	☞	8 1/2 × 13	☆	☆	☆
F/GL	☞	8 × 13	☆	☆	☆
Com#10 Env	☞	9 1/2 × 4 1/8	☆	×	×
C5 Env	☞	9.02 × 6.38	☆	×	×
C6 Env	☞	6.38 × 4.49	☆	×	×
DL Env	☞	8.66 × 4.33	☆	×	×
Monarch Env	☞	7 1/2 × 3 7/8	☆	×	×
Custom Size	-	-	★*	★	×
8K	☞	10 1/2 × 15.35	☆	☆	☆
16K	☞	7.68 × 10 1/2	☆	☆	☆
	☞	10 1/2 × 7.68	☆	☆	☆









- © means that the size is supported and the printer selects the paper size automatically.
- ☆ means that the size is supported but the paper size should be selected with the control panel.
- ★ means that the size is supported but the paper size should be set with the control panel as a custom size. The supported size is approximately 3.9 - 11.7 inches in width and 5.8 - 17 inches in length. The supported size may differ depending on the printer language you use.
- ★* means that the supported size is approximately 3.5 - 12 inches in width, and approximately 5.8 - 18 inches in length. The supported size may differ depending on the printer language you use. Make the custom size setting with the control panel.
- × means that the size is not supported.





















❖ Paper weight and number of sheets to be set

	Supported paper weight	Maximum number of sheets (plain paper) *1
Tray 1	64 - 105 g/m ² (17 - 28 lb. Bond)	250 (80 g/m ² , 20 lb. Bond)
Bypass Tray	64 - 163 g/m ² (17 lb. Bond - 90 lb. Index)	100 (80 g/m ² , 20 lb. Bond)
PAPER FEED UNIT Type 5000	64 - 105 g/m ² (17 - 28 lb. Bond)	500 (80 g/m ² , 20 lb. Bond)

*1 Confirm that the top of the stack is not higher than the limit mark inside the tray.

❖ Output Paper Sizes (Metric version)

	Feed direction	Size (mm)	Standard Tray	Finisher Straight	Finisher Shift	Finisher Staple	4-bin Mailbox
A3		297 × 420	○	○	×	×	○
B4 JIS		257 × 364	○	○	○	○	○
A4		210 × 297	○	○	○	○	○
		297 × 210	○	○	○	○	○
B5 JIS		182 × 257	○	○	×	×	○
		257 × 182	○	○	○	○	○
A5		148 × 210	○	×	×	×	○
		210 × 148	○	○	×	×	○
B6 JIS		128 × 182	○	×	×	×	×

	Feed direction	Size (mm)	Standard Tray	Finisher Straight	Finisher Shift	Finisher Staple	4-bin Mailbox
A6		105 × 148	○	×	×	×	×
11 × 17 inches		279 × 432	○	○	○	○	○
Legal (LG, 8 ¹ / ₂ × 14 inches)		216 × 356	○	○	○	○	○
Letter (LT, 8 ¹ / ₂ × 11 inches)		216 × 279	○	○	○	○	○
		279 × 216	○	○	○	○	○
5 ¹ / ₂ × 8 ¹ / ₂ inches		140 × 216	○	×	×	×	○
		216 × 140	○	×	×	×	○
Executive (Exec., 7 ¹ / ₄ × 10 ¹ / ₂ inches)		184 × 276	○	○	×	×	○
		276 × 184	○	×	×	×	○
Folio (8 ¹ / ₄ × 13 inches)		210 × 330	○	×	×	×	○
Foolscap (F4, 8 ¹ / ₂ × 13 inches)		216 × 330	○	○	○	○	○
F/GL (8 × 13 inches)		203 × 330	○	○	×	×	○
Com#10 Env (4 ¹ / ₈ × 9 ¹ / ₂ inches)		104.8 × 241.3	○	×	×	×	×
C5 Env (6.38 × 9.02 inches)		162 × 229	○	×	×	×	×
C6 Env (4.49 × 6.38 inches)		114 × 162	○	×	×	×	×
DL Env (4.33 × 8.66 inches)		110 × 220	○	×	×	×	×
Monarch Env (3 ⁷ / ₈ × 7 ¹ / ₂ inches)		98.4 × 190.5	○	×	×	×	×
Custom Size	-	-	○	×	×	×	×
8K (10 ¹ / ₂ × 15.35 inches)		267 × 390	○	○	○	○	○
16K (7.68 × 10 ¹ / ₂ inches)		195 × 267	○	○	×	×	○
		267 × 195	○	○	○	○	○

- ○ means that the size is supported.
- × means that the size is not supported.

◆ Output Paper Sizes (Inch version)

	Feed direction	Size (inch)	Standard Tray	Finisher Straight	Finisher Shift	Finisher Staple	4-bin Mailbox
11 × 17 inches	☞	11 × 17	○	○	○	○	○
Legal (LG, 8 1/2 × 14 inches)	☞	8 1/2 × 14	○	○	○	○	○
Letter (LT, 8 1/2 × 11 inches)	☞	8 1/2 × 11	○	○	○	○	○
	☞	11 × 8 1/2	○	○	○	○	○
5 1/2 × 8 1/2 inches	☞	5 1/2 × 8 1/2	○	×	×	×	○
Executive (Exec.)	☞	7 1/4 × 10 1/2	○	○	×	×	○
	☞	10 1/2 × 7 1/4	○	×	×	×	○
A3	☞	11.69 × 16.54	○	○	×	×	○
B4 JIS	☞	10.12 × 14.33	○	○	○	○	○
A4	☞	5.83 × 8.26	○	○	○	○	○
	☞	8.26 × 5.83	○	○	○	○	○
B5 JIS	☞	7.17 × 10.12	○	○	○	○	○
	☞	10.12 × 7.17	○	○	×	×	○
A5	☞	5.83 × 8.26	○	×	×	×	○
	☞	8.26 × 5.83	○	○	×	×	○
B6 JIS	☞	5.04 × 7.17	○	×	×	×	×
A6	☞	4.13 × 5.63	○	×	×	×	×
Folio	☞	8 1/4 × 13	○	×	×	×	○
Foolscap F4	☞	8 1/2 × 13	○	○	○	○	○
F/GL	☞	8 × 13	○	○	×	×	○
Com#10 Env	☞	4 1/8 × 9 1/2	○	×	×	×	×
C6 Env	☞	4.49 × 6.38	○	×	×	×	×
C5 Env	☞	6.38 × 9.02	○	×	×	×	×
DL Env	☞	4.33 × 8.66	○	×	×	×	×
Monarch Env	☞	3 7/8 × 7 1/2	○	×	×	×	×
Custom Size	-	-	○	×	×	×	×
8K	☞	10 1/2 × 15.35	○	○	○	○	○
16K	☞	7.68 × 10 1/2	○	○	×	×	○
	☞	10 1/2 × 7.68	○	○	○	○	○

- ○ means that the size is supported.
- × means that the size is not supported.

Paper Recommendations

Loading Paper

Important

- Do not use paper that is meant for an ink-jet printer, or it may stick to the fusing unit and cause a paper misfeed.
- When printing on an OHP transparency that has a print side, be sure to print on the print side. Otherwise, it may stick to the fusing unit and cause a paper misfeed.
- Set the paper as described below:
 - Tray 1: Print side facing up
 - Paper Feed Unit: Print side facing up
 - Bypass Tray: Print side facing down
- Print quality cannot be guaranteed if paper other than the ones recommended is used. For more information about recommended paper, contact your sales or service representative.
- Do not use paper that has already been printed on by other printers.

Storing Paper

- Paper should always be stored properly. Improperly stored paper might result in poor print quality, paper misfeeds, or printer damage. Recommendations are as follows:
 - Avoid storing paper in humid areas.
 - Avoid exposing paper to direct sunlight.
 - Store on a flat surface.
- Keep paper in the package in which the paper came.

Types of Paper and Other Media

❖ Plain Paper

- Plain paper here means paper up to 105 g/m² (28 lb. Bond). When printing on paper less than 90 g/m² (24lb.Bond), make setting to select **[Normal]** with the control panel. When printing on paper between 90 to 105 g/m² (24 to 28lb.Bond), select **[>90g/m2, 24lb]** with the control panel. See “Maintenance Menu” in the Administrator Reference.
- Any input tray can be used.

- Tray 1 can hold up to 250 sheets.
PAPER FEED UNIT Type 5000 can hold up to 500 sheets.
(Up to two units can be installed to the printer.)
The Bypass Tray can hold up to 100 sheets.
Confirm that the top of the stack is not higher than the limit mark inside the tray.
- Tray 1 supports custom size paper approximately 100 to 297 mm (3.9 to 11.7 inches) in width and 148 to 432 mm (5.8 to 17 inches) in length.
- The Bypass Tray supports custom size paper approximately 90 to 305 mm (3.5 to 12 inches) in width, and approximately 148 to 457 mm (5.8 to 18 inches) in length.
- When printing on the reverse side of plain paper that has been already printed on, load it on the Bypass Tray with print side down, and then select **[Plain (Duplex Backside)]** with the control panel or the printer driver. Only the Bypass Tray supports this function.

❖ Thick Paper

- Thick paper here means paper between 106 g/m² (28 lb. Bond) to 163 g/m² (90 lb. Index).
- Use of the Bypass Tray is recommended. Tray 1 can also be used. The Paper Feed Unit cannot be used.
- Tray 1 can hold up to 50 sheets. The Bypass Tray can hold up to 30 sheets.
- The Bypass Tray can hold paper up to 163 g/m² (90 lb. Index) in weight. The print quality is not guaranteed for paper thicker than this.
- Confirm that the top of the stack is not higher than the limit mark inside the tray.
- When printing on thick paper, select the thick paper mode with the control panel or the printer driver.
- When printing on the reverse side of thick paper that has been already printed on, load it on the Bypass Tray with print side down, and then select **[Thick (Duplex Backside)]** with the control panel or the printer driver. Only the Bypass Tray supports this function.

Note

- The number of sheets to be set may vary depending on the paper thickness and paper type.
- There may be noise when printing on thick paper. This is not a malfunction.

❖ OHP transparencies

- Use of the Bypass Tray is recommended. Tray 1 can also be used. The Paper Feed Unit cannot be used.
- Tray 1 can hold up to 20 sheets. The Bypass Tray can hold up to 50 sheets.
- We recommend that you load OHP transparencies in the direction of .
- Separate stuck OHP transparencies every time before printing.
- If OHP transparencies stick together when they feed, set them on the tray one by one or select "Slip sheet" in the printer driver. For more information about using "Slip sheet", see the printer driver's Help file.
- Confirm that the top of the stack is not higher than the limit mark inside the tray.
- When printing on OHP transparencies, select the OHP transparency mode with the control panel or the printer driver.
- Remove OHP transparencies from the tray after use to prevent them from sticking to each other.

❖ Envelopes

- Use the Bypass Tray. Tray 1 and the Paper Feed Unit cannot be used.
- The Bypass Tray can hold up to 10 envelopes.
- The length from the bottom of the envelope to the tip of the flap must be 140 mm (5.5 inches) or longer.
- Load envelopes in the Bypass Tray with the print side down, the flaps open and the bottoms in the feeding direction.

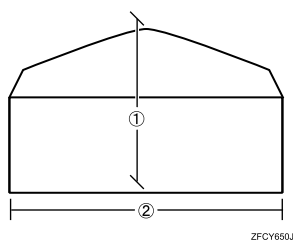

① : Must be 140 mm (5.5 inches) or longer.

② : Must be 241.3 mm (9 1/2 inches) or shorter.

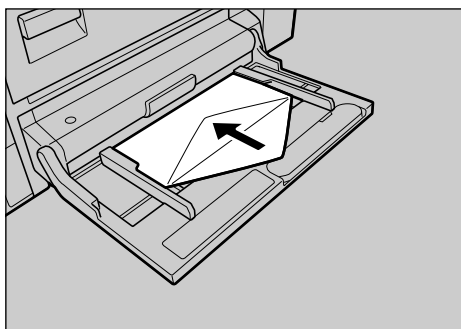

- Load only one size and type of envelope at a time.
- Do not forcibly push envelopes when loading.
- Confirm that the top of the stack is not higher than the limit mark inside the tray.
- Use flat envelopes with no curl. If they have a curl, flatten them.
- Use completely flat envelopes that contain no air inside.
- Do not print on both sides of envelopes.
- Do not use the following envelopes:
 - Envelopes with multiple flaps
 - Envelopes with a peel-off adhesive strip
 - Envelopes with windows or clasps
 - Envelopes made of paper that is not supported by this printer (See p.10 “Paper not supported by this printer”)
- We recommend setting the margins to at least 15 mm (0.6 inch) for all four directions.
- Envelopes are output to the standard output tray only.
- Envelopes may wrinkle or print quality may be poor depending on the characteristics of the envelope such as weight and stiffness.
- See p.1 “Paper Sizes” for the supported sizes of envelopes.
- Make the printer driver’s setting for rotating the print image by 180 degrees. For details, see the Help file for the printer driver.

❖ **Paper not supported by this printer**

Avoid using the following paper as they are not supported by this printer.

- Paper meant for an ink-jet printer
- Bent, folded, or creased paper
- Curled or twisted paper
- Torn paper
- Wrinkled paper
- Damp paper
- Paper that is dry enough to emit static electricity
- Paper that has already been printed onto, except a preprinted letterhead
- Special paper, such as thermal paper, aluminum foil, carbon paper and conductive paper
- Paper whose weight is heavier or lighter than the limitation.
- Paper with windows, holes, perforations, cutouts, or embossing
- Adhesive label paper on which glue or base paper is exposed
- Paper with clips or staples

Printable Area

The following shows the printable area for this printer. Be sure to set the print margins correctly by the application.

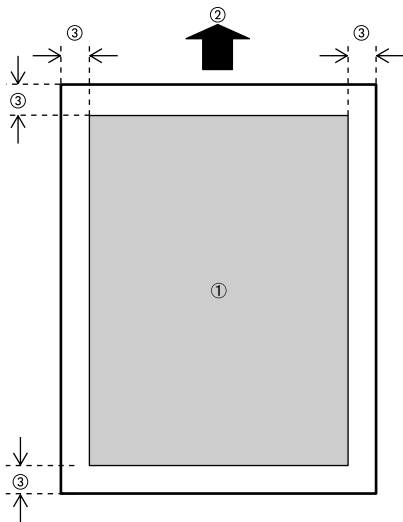

- ① : Printable area
- ② : Feed direction
- ③ : Approx. 5 mm (0.2 inch)

 **Note**

- The printable area may vary depending on the paper size, printer language and printer driver settings.

Loading Paper

1

⚠ CAUTION:

- The inside of the machine becomes very hot. Do not touch the inner surface with "⊘" and "⚠" labels indicating a hot surface. Touching that surface could result in a burn.

🔍 Reference

See p.1 "Paper Sizes" for the paper sizes that can be loaded in Tray 1.

Loading Paper in Tray 1

📌 Note

- ❑ When using thick paper or OHP transparencies, select each mode using the control panel or the printer driver. See p.17 "Specifying a paper type" for using the control panel. See the Help file of the printer driver for using the printer driver.

Loading paper in the paper tray

- 1** Pull out the paper tray slowly until it stops.

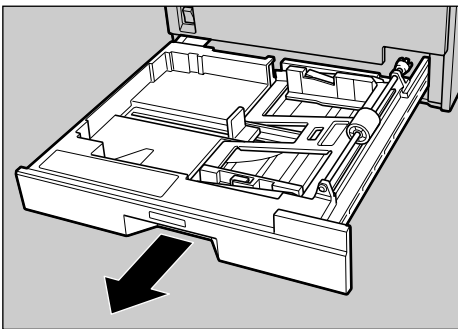

- 2** Lower the base panel by pushing "Push". When paper is set in the tray, push down on the paper.

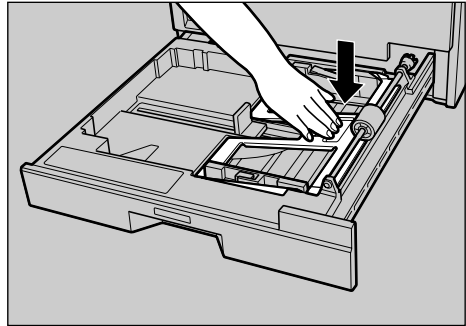

- 3** Load paper into the tray with the print side up.

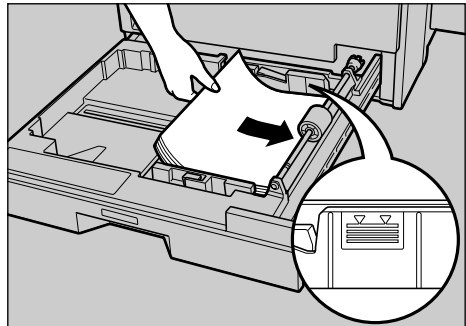

⚠ Important

- ❑ Confirm that the top of the stack is not higher than the limit mark inside the tray.

- 4** Slide the paper tray into the printer carefully until it stops.

Changing paper size of the paper tray

- 1** Pull out the paper tray slowly until it stops.

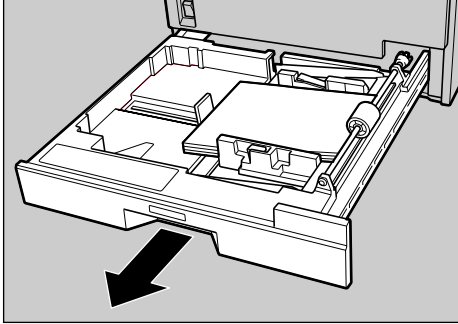

ZESH305J

- 2** Lower the base panel by pushing "Push". When paper is set in the tray, push down on the paper.

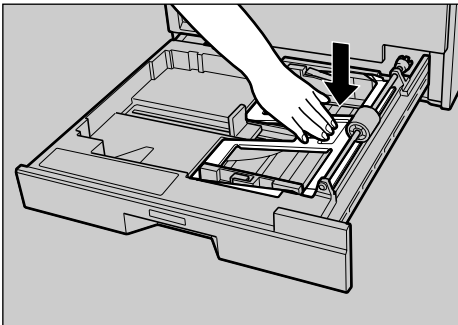

ZESH470J

- 3** When paper is set in the tray, remove them.

- 4** Set the paper guide lock to the "unlocked" position.

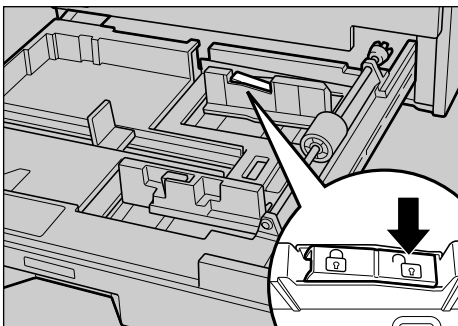

ZESY950J

- 5** Pushing the green lever of the side guide (①), move the side guide toward you to open it (②).

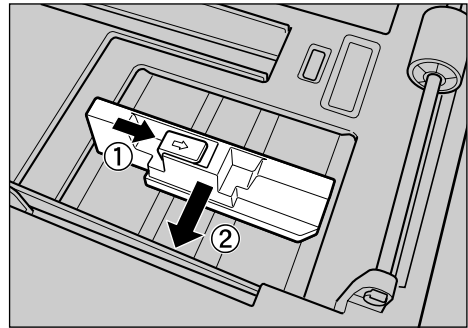

ZESY602J

- 6** Pinching both sides of the end guide (①), move the end guide in the direction of the arrow (②) to open it.

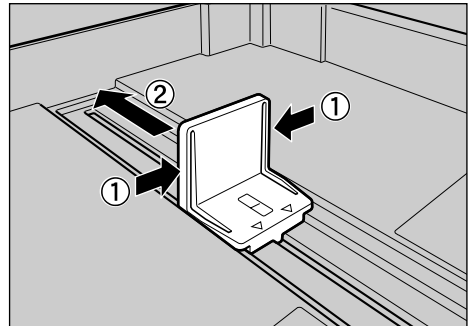

ZESY801J

- 7** Load paper into the tray with the print side up.

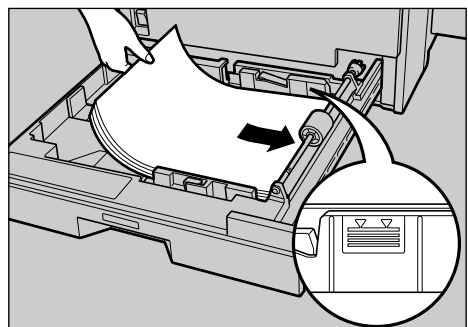

ZESY004J

Important

- Confirm that the top of the stack is not higher than the limit mark inside the tray.

8 Pushing the green lever of the side guide (①), move the side guide toward the paper stack until it stops (②).

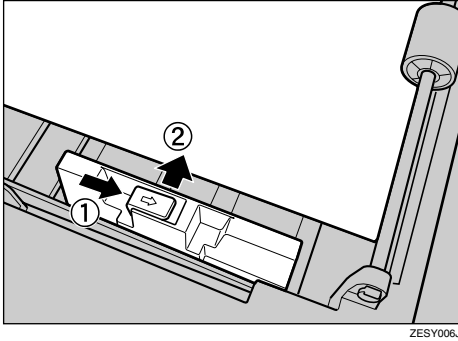

9 Confirm that the paper is fixed in place, and then lock the side guides.

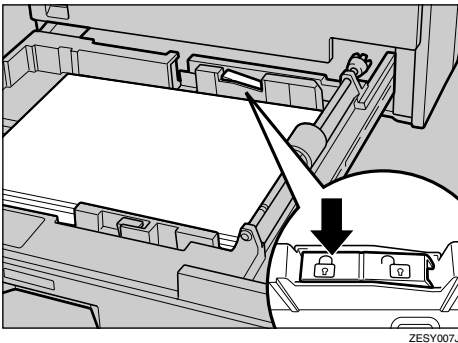

10 Pinching both sides of the end guide (①), move the end guide toward the paper stack until it stops (②).

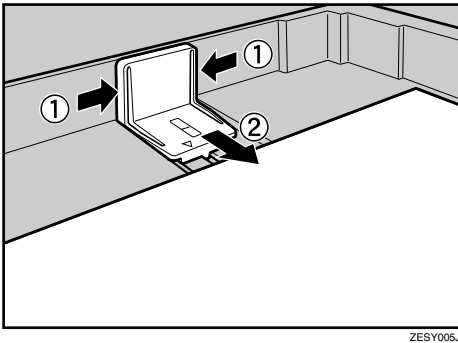

11 Slide the paper tray into the printer carefully until it stops.

Important

- Do not slide the paper tray in with force. If you do, the front and side guides might move.

Specifying paper not supported by the auto selection

Specify the paper size with the control panel when you load paper that is not supported by the auto selection.

Note

- See p.1 "Paper Sizes" for the paper sizes that are not supported by the auto selection.

Reference

See p.13 "Changing paper size of the paper tray" for more information about how to load paper.

This section uses 8 1/2 x 5 1/2 inch paper as an example.

1 Press [Menu].

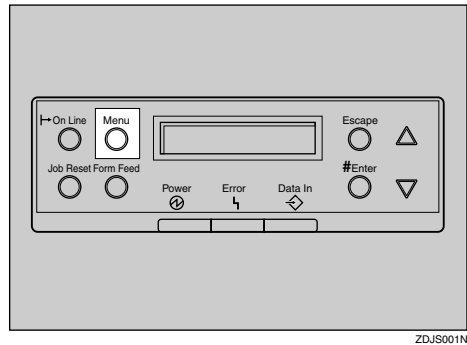

"Menu" appears on the panel display.

2 Press [▲] or [▼] to display "Paper Input", and then press [Enter #].

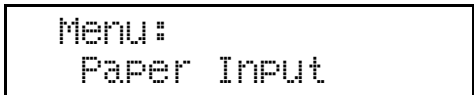

- 3** Press **[▲]** or **[▼]** to display "Tray Paper Size", and then press **[Enter #]**.

```
Paper Input:
Tray Paper Size
```

- 4** Press **[▲]** or **[▼]** to display "Tray 1", and then press **[Enter #]**.

```
Tray Paper Size:
Tray 1
```

- 5** Press **[▲]** or **[▼]** to display the loaded paper size and direction, and then press **[Enter #]**.

```
Tray 1:
8 1/2 X 5 1/2
```

 **Note**

- The default is "Auto".

In about two seconds, the display returns to the menu.

- 6** Press **[On Line]**.

"Ready" appears on the panel display.

```
Ready
```

This completes the change in setting.

 **Important**

- If you want to use paper that is supported by the auto selection after printing on paper that is not supported by the auto selection, load the paper and go to step **7** to reset the setting using the control panel.

- 7** Press **[Menu]**.

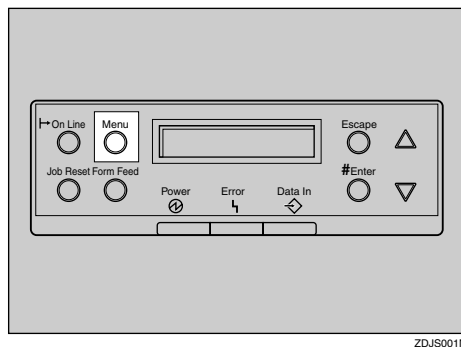

"Menu" appears on the panel display.

- 8** Press **[▲]** or **[▼]** to display "Paper Input", and then press **[Enter #]**.

```
Menu:
Paper Input
```

- 9** Press **[▲]** or **[▼]** to display "Tray Paper Size", and then press **[Enter #]**.

```
Paper Input:
Tray Paper Size
```

- 10** Press **[▲]** or **[▼]** to display "Tray 1", and then press **[Enter #]**.

```
Tray Paper Size:
Tray 1
```

- 11** Press **[▲]** or **[▼]** to display "~~X~~Auto", and then press **[Enter #]**.

```
Tray 1
*Auto
```

In about two seconds, the display returns to the menu.

12 Press [On Line].

"Ready" appears on the panel display.



Specifying a custom paper size

Specify the paper size with the control panel when you load custom size paper.

Important

- ❑ The paper size selected with the printer driver overrides the one selected with the control panel. You do not have to make settings with the control panel if you have already made them with the printer driver. However, when printing with a printer driver other than the RPCS printer driver, you must make the settings using the control panel. For more information about the printer driver, see the Help file.
- ❑ The maximum custom paper size supported by Tray 1 is smaller than that supported by the Bypass Tray. When printing on custom size paper using Tray 1, and the size set with the printer driver is larger than the size supported by Tray 1, the areas beyond the supported size may not be printed. In such a case, use the Bypass Tray.
- ❑ The printer cannot print from applications that do not support custom paper size.

- ❑ Set the vertical value for (1), and set the horizontal value for (2).

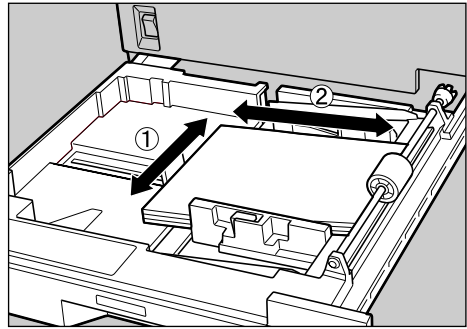

ZESY008J

1 Press [Menu].

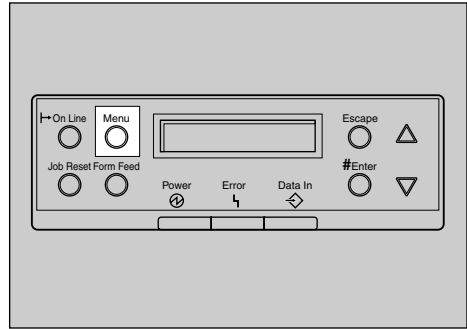

ZDJS001N

"Menu" appears on the panel display.

2 Press [▲] or [▼] to display "Paper Input", and then press [Enter #].



3 Press [▲] or [▼] to display "Tray Paper Size", and then press [Enter #].



4 Press [▲] or [▼] to display "Tray 1", and then press [Enter #].

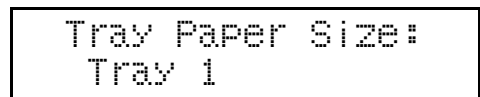

- 5** Press **[▲]** or **[▼]** to display "Custom Size", and then press **[Enter #]**.

```
Tray 1
Custom Size
```

- 6** Press **[▲]** or **[▼]** to set the vertical value, and then press **[Enter #]**.

```
Custom Size
Vert. 150 mm
```

The unit on the panel display can be changed to inches with the control panel.

- 7** Press **[▲]** or **[▼]** to set the horizontal value, and then press **[Enter #]**.

```
Custom Size
Horiz. 200 mm
```

After about two seconds, the display returns to the menu.

- 8** Press **[On Line]**.

"Ready" appears on the panel display.

```
Ready
```

Specifying a paper type

By selecting the paper type you want to load, the printer can execute better printing. You can select from the following paper types.

- Plain Paper, Recycled Paper, Special Paper, Color Paper, Letterhead, Preprinted, Prepunched, Bond Paper, Labels (adhesive label paper), Transparency (OHP transparency), Thick Paper

Important

- You must specify the paper type when using thick paper, adhesive label paper, or OHP transparencies.

- 1** Press **[Menu]**.

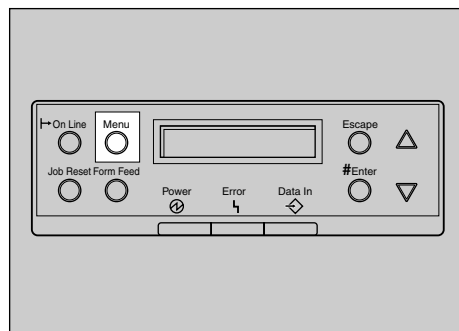

"Menu" appears on the panel display.

- 2** Press **[▲]** or **[▼]** to display "Paper Input", and then press **[Enter #]**.

```
Menu:
Paper Input
```

- 3** Press **[▲]** or **[▼]** to display "Paper Type", and then press **[Enter #]**.

```
Paper Input:
Paper Type
```

- 4** Press **[▲]** or **[▼]** to display "Tray 1", and then press **[Enter #]**.

```
Paper Type:
Tray 1
```

- 5** Press **[▲]** or **[▼]** to display the loaded paper type, and then press **[Enter #]**.

```
Tray 1
Recycled Paper
```

In about two seconds, the display returns to the menu.

1

6 Press **[On Line]**.

"Ready" appears on the panel display.



Loading Paper in the Optional Paper Feed Unit

⚠ CAUTION:

- *The inside of the machine becomes very hot. Do not touch the inner surface with "⊘" and "⚠" labels indicating a hot surface. Touching that surface could result in a burn.*

🔧 Note

- When you pull out the paper tray with paper set in it, pull it out slowly. Pulling out with force may cause the top sheet to be torn.

🔍 Reference

See p.1 "Paper Sizes" for the paper sizes that can be loaded in the optional Paper Feed Unit.

Loading paper in the paper tray

1 Pull out the paper tray slowly until it stops.

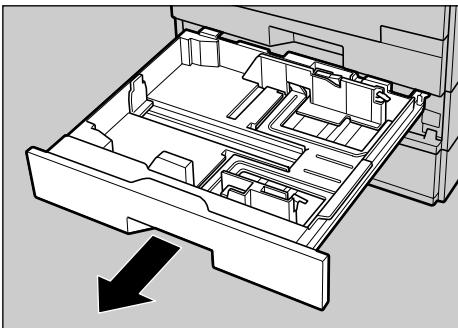

ZESH471J

2 Load paper into the tray with the print side up.

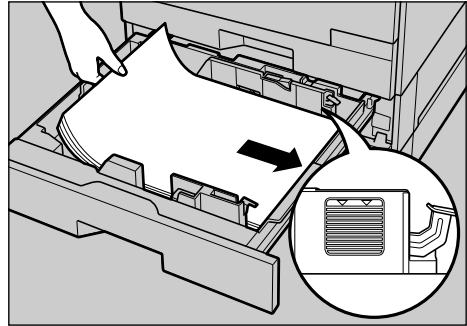

ZESH472J

⚠ Important

- Confirm that the top of the stack is not higher than the limit mark inside the tray.

3 Slide the paper tray into the printer carefully until it stops.

Changing paper size of the paper tray

1 Pull out the paper tray slowly until it stops.

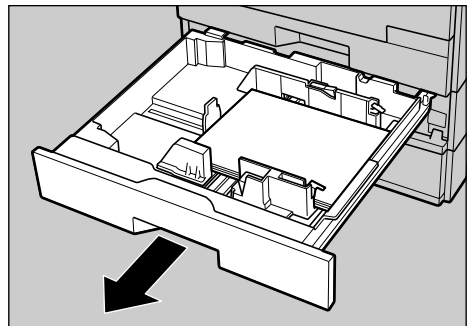

ZESH473J

2 When paper is set in the tray, remove them.

- 3** Set the paper guide lock to the "unlocked" position.



ZESH474J

- 6** Load paper into the tray with the print side up.

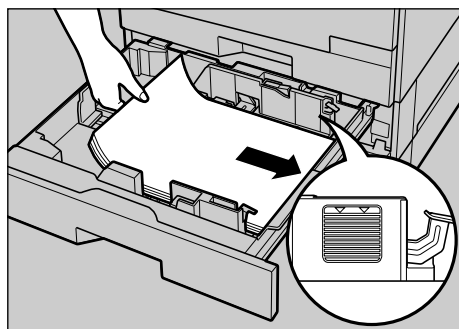

ZESH477J

- 4** Pushing the green lever of the side guide (①), move the side guide toward you to open it (②).

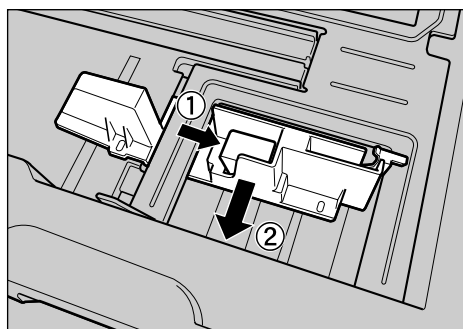

ZESH475J

Important

- Confirm that the top of the stack is not higher than the limit mark inside the tray.

- 7** Pushing the green lever of the side guide (①), move the side guide toward the paper stack until it stops (②).

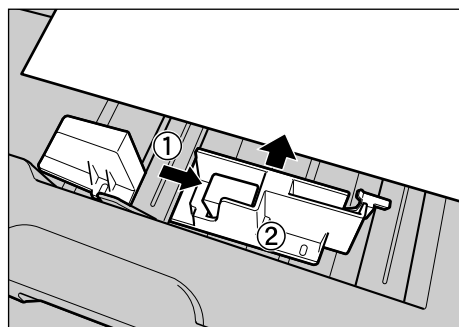

ZESH478J

- 5** Pinching both sides of the end guide (①), move the end guide in the direction of the arrow (②) to open it.

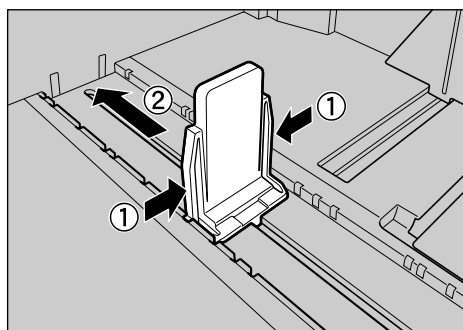

ZESH476J

1

8 Confirm that the paper is fixed in place, and then lock the side guides.

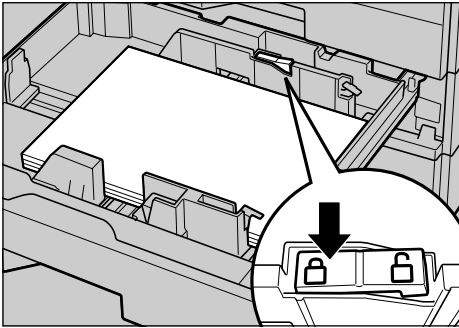

ZESH479J

9 Pinching both sides of the end guide (1), move the end guide toward the paper stack until it stops (2).

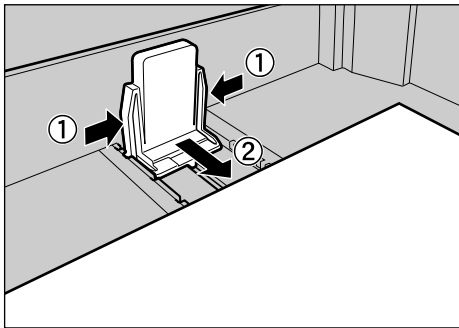

ZESH480J

10 Slide the paper tray into the printer carefully until it stops.

Important

- Do not slide the paper tray in with force. If you do, the front and side guides might move.

Specifying paper not supported by the auto selection

Specify the paper size with the control panel when you load paper that is not supported by the auto selection.

Note

- See p.1 "Paper Sizes" for the paper sizes that are not supported by the auto selection.

Reference

See p.13 "Changing paper size of the paper tray" for more information about how to load paper.

This section uses B5 (7.17 × 10.12 inches) paper as an example.

1 Press [Menu].

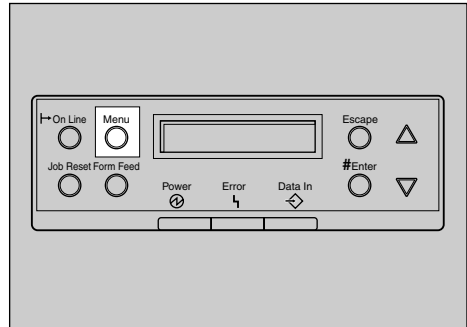

ZDJS001N

"Menu" appears on the panel display.

2 Press [▲] or [▼] to display "Paper Input", and then press [Enter #].



3 Press [▲] or [▼] to display "Tray Paper Size", and then press [Enter #].



- 4** Press **[▲]** or **[▼]** to display "Tray 2" or "Tray 3" depending on the tray that you loaded the paper in, and then press **[Enter #]**.

```
Tray Paper Size:
Tray 2
```

Note

- Display "Tray 3" when using the second tray of the Paper Feed Unit when two of them are installed. Display "Tray 2" in other cases.

- 5** Press **[▲]** or **[▼]** to display the loaded paper size and direction, and then press **[Enter #]**.

```
Tray 2:
B5 (182 x 257)
```

Note

- The default is "Auto".

In about two seconds, the display returns to the menu.

- 6** Press **[On Line]**.

"Ready" appears on the panel display.

```
Ready
```

This completes the change in setting.

Important

- If you want to use paper that is supported by the auto selection after printing on paper that is not supported by the auto selection, load the paper and go to step **7** to reset the setting using the control panel.

- 7** Press **[Menu]**.

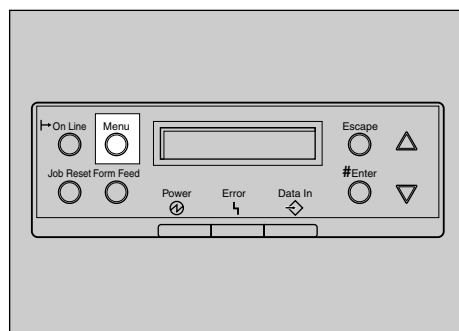

"Menu" appears on the panel display.

- 8** Press **[▲]** or **[▼]** to display "Paper Input", and then press **[Enter #]**.

```
Menu:
Paper Input
```

- 9** Press **[▲]** or **[▼]** to display "Tray Paper Size", and then press **[Enter #]**.

```
Paper Input:
Tray Paper Size
```

- 10** Press **[▲]** or **[▼]** to display the tray that you want to reset the setting to, and then press **[Enter #]**.

```
Tray Paper Size:
Tray 2
```

- 11** Press **[▲]** or **[▼]** to display "~~*~~Auto", and then press **[Enter #]**.

```
Tray 2
*Auto
```

In about two seconds, the display returns to the menu.

1

12 Press **[On Line]**.

"Ready" appears on the panel display.



Specifying a paper type

By selecting the paper type you want to load, the printer can execute better printing. You can select from the following paper types.

- Plain Paper, Recycled Paper, Special Paper, Color Paper, Letterhead, Preprinted, Prepunched, Bond Paper

Note

- When selecting "Plain Paper", select either "Normal" or ">90g/m2, 24lb" for "Plain Paper Type" in the "Maintenance" menu.

1 Press **[Menu]**.

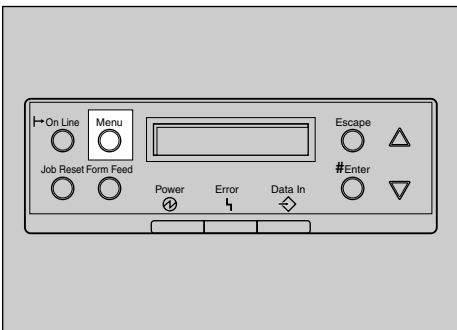

"Menu" appears on the panel display.

2 Press **[▲]** or **[▼]** to display "Paper Input", and then press **[Enter #]**.

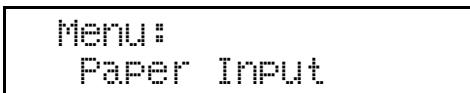

3 Press **[▲]** or **[▼]** to display "Paper Type", and then press **[Enter #]**.



4 Press **[▲]** or **[▼]** to display "Tray 2" or "Tray 3" depending on the tray that you loaded the paper in, and then press **[Enter #]**.

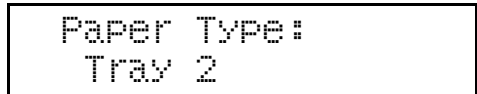

Note

- Display "Tray 3" when using the second tray of the Paper Feed Unit when two of them are installed. Display "Tray 2" in other cases.

5 Press **[▲]** or **[▼]** to display the loaded paper type, and then press **[Enter #]**.

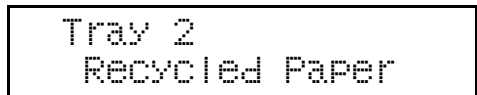

In about two seconds, the display returns to the menu.

6 Press **[On Line]**.

"Ready" appears on the panel display.



Loading Paper in the Bypass Tray

In addition to plain paper, you can load thick paper, envelopes, OHP transparencies, and paper that is longer than A3 (11.69 × 16.54 inches) onto the Bypass Tray.

Note

- ❑ Paper sizes supported by the Bypass Tray are 90 - 305 mm (3.5 - 12 inches) in width, and 148 - 457 mm (5.8 - 18 inches) in length.
- ❑ The paper size selected with the printer driver overrides the one selected with the control panel. You do not have to make settings with the control panel if you have already made them with the printer driver. However, when using a printer driver other than the RPCS printer driver, you must make the settings using the control panel. For more information about the printer driver, see the Help file. See p.24 "Specifying a custom paper size for the Bypass Tray".
- ❑ If you load thick paper, OHP transparencies, labels or the reverse side of plain or thick paper that has been already printed on, make the settings for each paper type with the control panel or the printer driver. See p.25 "Specifying a paper type for the Bypass Tray".
- ❑ The number of pages that can be loaded in the Bypass Tray differs depending on the paper type. Confirm that the top of the stack is not higher than the limit mark inside the tray.

1 Open the Bypass Tray.

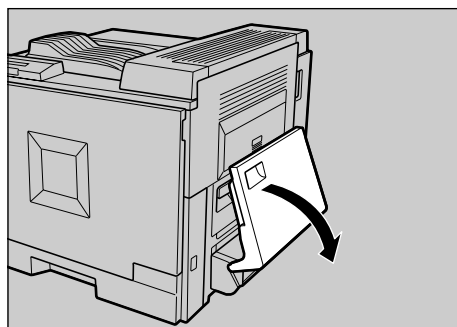

ZESH206J

Note

- ❑ If you load A4/letter or larger size paper, pull out the Bypass Tray extension, and then flip it open.

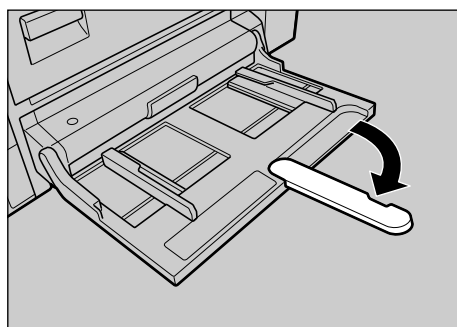

ZESH203J

2 Slide the side guides outward (1), and then load paper until it stops with the print side down (2).

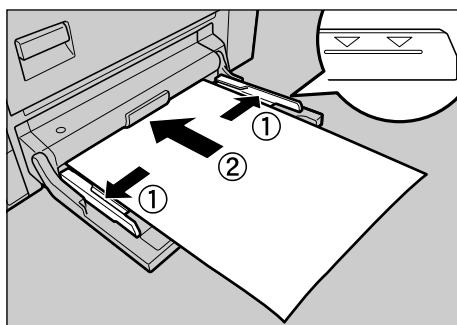

ZESH204J

1

- 3 Adjust the side guides to the paper width.

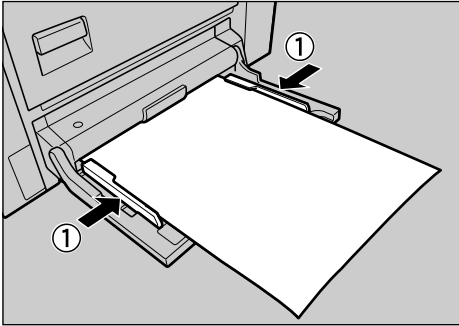

ZESH205J

Important

- Confirm that the top of the stack is not higher than the limit mark inside the tray.
- Shuffle the paper before loading the stack onto the tray so multiple sheets are not fed in at one time.

- 4 Set the paper size using the control panel as follows:

- 1 Press **[Menu]**.

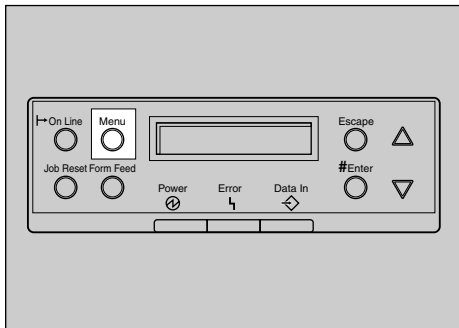

ZDJ9001N

"Menu" appears on the panel display

- 2 Press **[▲]** or **[▼]** to display "Paper Input", and then press **[Enter #]**.

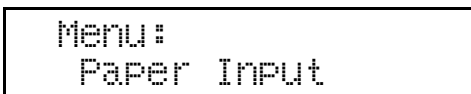

- 3 Confirm that "Bypass Size" is displayed, and then press **[Enter #]**.

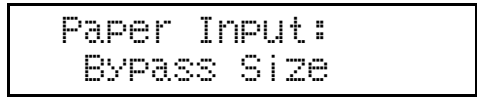

- 4 Press **[▲]** or **[▼]** to display the size and direction of the paper in the Bypass Tray.

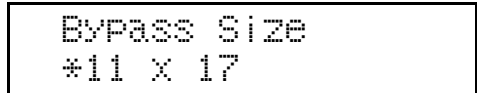

In about two seconds, the display returns to the menu.

- 5 Press **[On Line]**.

"Ready" appears on the panel display.



Specifying a custom paper size for the Bypass Tray

Specify the paper size with the control panel when you load custom size paper.

Important

- The paper size selected with the printer driver overrides the one selected with the control panel. You do not have to make settings with the control panel if you have already made them with the printer driver. However, when printing with a printer driver other than the RPCS printer driver, you must make the settings using the control panel. For more information about the printer driver, see the Help file.
- The printer cannot print from applications that do not support custom paper size.

- Set the vertical value for (①), and set the horizontal value for (②).

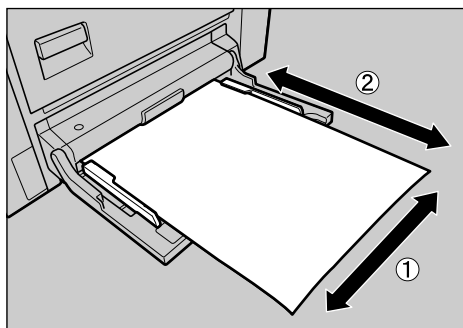

ZESY009J

- 1** Press **[Menu]**.

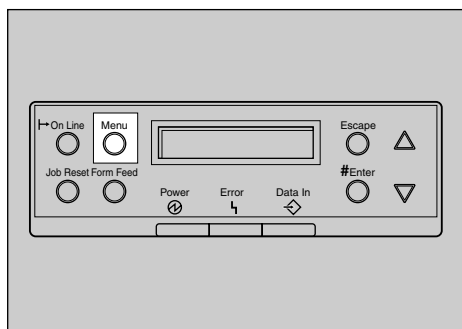

ZDJS001N

"Menu" appears on the panel display.

- 2** Press **[▲]** or **[▼]** to display "Paper Input", and then press **[Enter #]**.

```
Menu:
Paper Input
```

- 3** Confirm that "Bypass Size" is displayed, and then press **[Enter #]**.

```
Paper Input:
Bypass Size
```

- 4** Press **[▲]** or **[▼]** to display "Custom Size", and then press **[Enter #]**.

```
Bypass Size:
Custom Size
```

- 5** Press **[▲]** or **[▼]** to set the vertical value, and then press **[Enter #]**.

```
Custom Size:
Vert.      150mm
```

The unit on the panel display can be changed to inches with the control panel.

- 6** Press **[▲]** or **[▼]** to set the horizontal value, and then press **[Enter #]**.

```
Custom Size:
Horiz.    200mm
```

In about two seconds, the display returns to the menu.

- 7** Press **[On Line]**.

"Ready" appears on the panel display.

```
Ready
```

Specifying a paper type for the Bypass Tray

By selecting the paper type you want to load, the printer can execute better printing. You can select from the following paper types.

- Plain Paper, Recycled Paper, Special Paper, Color Paper, Letterhead, Preprinted, Prepunched, Bond Paper, Labels (adhesive label paper), Transparency (OHP transparency), Thick Paper, Plain: Dup. Back (reverse side of plain paper), Thick: Dup. Back (reverse side of thick paper)

1

Important

- ❑ You must specify the paper type when using thick paper, adhesive label paper, OHP transparencies or the reverse side of plain or thick paper that has already been printed on.

Note

- ❑ When selecting "Plain Paper", select either "Normal" or ">90g/m2, 24lb" for "Plain Paper Type" in the "Maintenance" menu.

1 Press **[Menu]**.

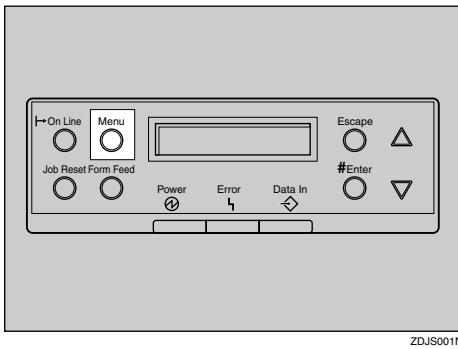

"Menu" appears on the panel display.

2 Press **[▲]** or **[▼]** to display "Paper Input", and then press **[Enter #]**.

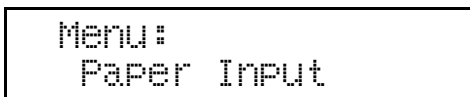

3 Press **[▲]** or **[▼]** to display "Paper Type", and then press **[Enter #]**.

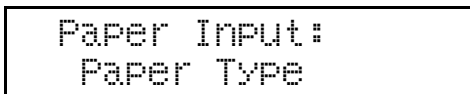

4 Press **[▲]** or **[▼]** to display "Bypass Tray", and then press **[Enter #]**.



5 Press **[▲]** or **[▼]** to display the loaded paper type, and then press **[Enter #]**.



In about two seconds, the display returns to the menu.

6 Press **[On Line]**.

"Ready" appears on the panel display.



2. Troubleshooting

Error & Status Messages on the Control Panel

◆ Status Messages

Messages/Second messages	Status
Calibrating...	The printer is calibrating the color. Wait until "Ready" appears on the panel display.
Colour is being adjusted	The printer is performing image adjustment operations. The printer may perform periodic maintenance during operations. The frequency and duration of maintenance depends on the humidity, temperature and printing factors such as number of prints, paper size, and paper type. Wait for the machine to get ready.
Energy Save Mode	The printer is in Energy Saver (low-power) mode. No action is required.
Hex Dump Mode	The printer receives data in hexadecimal numbers in Hex Dump mode. Turn off the printer after printing, and then turn back on.
Loading Toner...	The printer is loading toner. Wait until "Ready" appears on the panel display.
Offline	The printer is offline. Set the printer online by pressing [On Line] to start printing.
Please Wait	The printer is initializing the development unit. Wait for a while.
Printing...	The printer is making prints. Wait for a while.
Processing...	The printer is processing the print job. Wait for a while.
Ready	The default ready message. The printer is ready for use. No action is required.
Resetting Job...	The printer is resetting the print job. Wait until "Ready" appears on the panel display.
Self checking	The printer is performing image adjustment operations. The printer may perform periodic maintenance during operations. The frequency and duration of maintenance depends on the humidity, temperature and printing factors such as number of prints, paper size, and paper type. Wait for the machine to get ready.
Waiting...	The printer is waiting for the next data to print. Wait for a while.
Warming Up...	The printer is warming up and not ready. Wait until "Ready" appears on the panel display.

❖ Alert Messages

Messages/Second messages	Description	Solution
Add Staples	The staples have run out.	Add staples. See p.62 "Adding Staples".
Add Toner /Yellow/Magenta/Cyan/Black	The printer is out of the indicated toner(s).	Replace with a new toner cartridge of the indicated color(s). Even when yellow, magenta or cyan toner runs out, you can print in black and white using the black toner. See "Replacing Consumables and Maintenance Kit" in Maintenance Guide 1.
Change Setting Bypass	The paper size set in the Bypass Tray differs from the setting made.	Load paper of the selected size on the Bypass Tray, and then change the paper size setting with the control panel. Or press [Form Feed] several times until the tray with desired paper size appears on the panel display. Or press [Job Reset] to cancel the print job.
Change Setting Tray #	The paper size set in the indicated tray differs from the setting made. #: tray number	Load paper of the selected size in the indicated tray, and then change the paper size setting with the control panel. Or press [Form Feed] several times until the tray with desired paper size appears on the panel display. Or press [Job Reset] to cancel the print job.
Change Setting: Tray # /Paper Size: Paper Type:	The paper size or paper type set in the indicated tray differs from the setting made.	Load paper of the selected size and type in the Tray, and then change the paper setting with the control panel. Or press [Form Feed] several times until the tray with desired paper type and paper size appears on the panel display. Or press [Job Reset] to cancel the print job.
Close Duplex Unit Cover	The cover of the Duplex Unit is open.	Close the cover of the Duplex Unit.

Messages/Second messages	Description	Solution
Close Finisher Rear Cover	The rear cover of the Finisher is open.	Close the rear cover of the Finisher.
Close Finisher Right Cover	The right cover of the Finisher is open.	Close the right cover of the Finisher.
Close Finisher Upper Cover	The upper cover or the paper entrance cover of the Finisher is open.	Close the upper cover or the paper entrance cover of the Finisher.
Close Front Cover	The front cover of the printer is open.	Close the front cover of the printer.
Close Left Cover	The left cover of the printer is open.	Close the left cover of the printer.
Close Lower Right Cover	The right cover of the Paper Feed Unit is open.	Close the right cover of the Paper Feed Unit.
Close Mailbox Cover	The cover of the 4-bin Mailbox is open.	Close the cover of the 4-bin Mailbox.
Close Right Cover	The right cover of the printer is open.	Close the right cover of the printer.
Close Upper Right Cover	The upper right cover of the printer is open.	Close the upper right cover of the printer.
Error:Tray # Form Feed /Or Job Reset Then Power OffOn	There is a problem with the indicated tray. #: tray number	Press 【Form Feed】 to select another tray and make a print, or turn the power switch off and on. If the message appears again, contact your sales or service representative.
Error:Tray # Reset The Job /Then Power OffOn	There is a problem with the indicated tray. #: tray number	Press 【Job Reset】 to cancel the print job, and then turn the power switch off and on. If the message appears again, contact your sales or service representative.
Hardware Problem DIMM	The printer detected a DIMM sum value error.	Turn the power switch off and on. If the message appears again, contact your sales or service representative.
Hardware Problem Ethernet	The printer detected an Ethernet error.	Turn the power switch off and on. If the message appears again, contact your sales or service representative.

Messages/Second messages	Description	Solution
Hardware Problem Finisher	There is a problem with the finisher.	Turn the power switch off and on. If the message appears again, contact your sales or service representative.
Hardware Problem HDD	The printer detected a HDD Board error.	Remove and re-install the Printer Hard Disk correctly. If the message appears again, contact your sales or service representative. See the Option Setup Guide.
Hardware Problem IEEE1394	The printer detected an IEEE1394 Board error.	<p>Remove and re-install IEEE1394 Board correctly.</p> <ol style="list-style-type: none"> ① Confirm that 1394 Interface Unit Type4510 is attached to the computer correctly. See the Option Setup Guide. ② Confirm that the IEEE1394 interface cable is connected securely. ③ Restart the computer. If the message appears again even after executing above operation, go to the following steps. ④ Unplug the IEEE1394 interface cable which is connected to the printer. ⑤ Execute the utility tool for 1394 Interface Unit Type4510 which is stored in the following path in the CD-ROM labeled "Printer Drivers and Utilities". UTILITY\1394 <p> Important</p> <ul style="list-style-type: none"> <input type="checkbox"/> For more information about using the utility tool for IEEE1394, see the README file in the same directory in the CD-ROM. <p>If the message appears again, contact your sales or service representative.</p>

Messages/Second messages	Description	Solution
Hardware Problem NV-RAM	The printer detected a Memory Switch error.	Remove and re-install the NV-RAM.
Hardware Problem Option RAM	There is a problem with the optional Memory Unit.	Remove and re-install the optional Memory Unit. If the message appears again, contact your sales or service representative. See the Option Setup Guide
Hardware Problem Parallel I/F	There is a problem with the parallel interface.	If you use the parallel I/F, replace the interface cable that caused the error. If the message appears again, contact your sales or service representative.
Hardware Problem Tray 2	There is a problem with the paper lift motor of Tray 2.	Turn the power switch off and on. If the message appears again, contact your sales or service representative.
Hardware Problem Tray 3	There is a problem with the paper lift motor of Tray 3.	Turn the power switch off and on. If the message appears again, contact your sales or service representative.
Hardware Problem USB	There is a problem related to the Universal Serial Bus connection and hardware.	Remove and reinstall the USB board. If the message appears again, contact your sales or service representative.
Hardware Problem Wireless Board	An error has occurred in the optional 802.11b Interface Unit.	Remove and reinstall the IEEE 802.11b board. If the message appears again, contact your sales or service representative.
Invalid Password Try Again	The entered password is not correct.	Enter the correct password.
Load Paper Tray #	The indicated tray is out of paper. #: tray number	Load paper into the indicated paper tray.

Messages/Second messages	Description	Solution
Load Paper /Paper Size: Paper Type:	The paper size set in the indicated tray differs from the setting made.	Load paper of the selected size in the tray, and then change the paper size setting with the control panel. Or press 【Form Feed】 several times until the tray with desired paper size appears on the panel display. Or press 【Job Reset】 to cancel the print job.
	The paper type set in the indicated tray differs from the setting made.	Load paper of the selected type in the tray, and then change the paper type setting with the control panel. Or press 【Form Feed】 several times until the tray with desired paper type appears on the panel display. Or press 【Job Reset】 to cancel the print job.
Menu Protected Cannot Change	The menu is protected.	The setting cannot be changed for the selected menu.
No Files Exist	There are no files available for Sample Print job or Locked Print job.	You can check the error files in the error log.
Paper Invalid for Duplex:Tray# /Change Setting or Form Feed	The paper setting for the selected tray is not supported for duplex printing. #: tray number	Change the paper setting with the control panel. Or press 【Form Feed】 several times until the tray with supported paper setting appears on the panel display. Or press 【Job Reset】 to cancel the print job.
Remove Misfeed A: Internal Path /See Instructions in Front Cover	There is a misfeed in the printer.	Remove the misfed paper following the instructions inside the front cover. For more information, see p.52 "When "Remove Misfeed A: Internal Path" Appears".
Remove Misfeed B: Fusing Unit /See Instructions in Front Cover	There is a misfeed in the fusing unit.	Remove the misfed paper following the instructions inside the front cover. For more information, see p.54 "When "Remove Misfeed B: Fusing Unit" Appears".

Messages/Second messages	Description	Solution
Remove Misfeed R: Finisher /Open Finisher Cover	There is a misfeed in the Finisher.	Open the right cover or the upper cover of the Finisher and remove the misfed paper. For more information, see p.56 "When "Remove Misfeed R: Finisher" Appears".
Remove Misfeed W: Mailbox /Open Mailbox Cover	There is a misfeed in the 4-bin Mailbox tray.	Open the Mailbox cover and remove the misfed paper. For more information, see p.58 "When "Remove Misfeed W: Mailbox" Appears".
Remove Misfeed Y: Paper Tray /See Instructions in Front Cover	There is a misfeed in the specified input tray, or the printer is not feeding paper.	Remove the misfed paper following the instructions inside the front cover. For more information, see p.57 "When "Remove Misfeed Y: Paper Tray" Appears".
Remove Misfeed Z: Duplex Unit /See Instructions in Front Cover	There is a misfeed in the Duplex Unit.	Remove the misfed paper following the instructions inside the front cover. For more information, see p.57 "When "Remove Misfeed Z: Duplex Unit" Appears".
Remove Paper All Output Trays	All output trays are full.	Remove paper from all output trays.
Remove Paper Duplex Unit	There is paper left in the Duplex Unit.	Remove paper from the Duplex Unit.
Remove Paper Finisher Tray	The output tray of the optional Finisher is full.	Remove paper from the Finisher tray.
Remove Paper Inside Finisher	There is paper left in the Finisher.	Remove paper from the Finisher. See p.56 "When "Remove Misfeed R: Finisher" Appears".
Remove Paper Mailbox Tray #	The output tray # of the optional 4-bin Mailbox is full. #: Mailbox tray number	Remove paper from the indicated 4-bin Mailbox tray.
Remove Paper Standard Tray	The standard output tray is full.	Remove paper from the standard output tray.
Remove Sealing Strip /Yellow/Magenta/Cyan/Black	The tape is still placed on the toner cartridge after the color(s) of the development unit is installed.	Remove the tape from the toner cartridge. See the Quick Installation Guide or "Replacing Consumables and Maintenance Kit" in Maintenance Guide 1.

Messages/Second messages	Description	Solution
Replace Development Unit /Yellow/Magenta/Cyan/Black	It is time to replace the indicated development unit.	Replace the indicated development unit with a new one. See "Replacing Consumables and Maintenance Kit" in Maintenance Guide 1.
Replace Black Development Unit	It is time to replace the black development unit.	Replace the black development unit with a new one. See " Replacing Consumables and Maintenance Kit" in Maintenance Guide 1.
Replace Black Develop.Unit soon	The printer is almost out of black development unit.	Prepare a new black development unit.
Replace Charger	It is time to replace charger.	Contact your sales or service representative.
Replace Cyan Development Unit	It is time to replace the cyan development unit.	Replace the cyan development unit with a new one. See " Replacing Consumables and Maintenance Kit" in Maintenance Guide 1.
Replace Cyan Develop.Unit soon	The printer is almost out of cyan development unit.	Prepare a new cyan development unit.
Replace Fuser Oil Unit	It is time to replace the fuser oil unit.	Replace the fuser oil unit with a new one. See "Replacing Consumables and Maintenance Kit" in Maintenance Guide 1.
Replace Fuser Oil Unit soon	The printer is almost out of fuser oil unit.	Prepare a new fuser oil unit.
Replace Fusing Unit /See Instructions before replacing	It is time to replace the fusing unit	Replace the fusing unit with a new one. See "Replacing Consumables and Maintenance Kit" in Maintenance Guide 1.
Replace Fusing Unit soon	It is time to replace the fusing unit soon.	Prepare a new fusing unit.
Replace Magenta Development Unit	It is time to replace the magenta development unit.	Replace a new magenta development unit. See " Replacing Consumables and Maintenance Kit" in Maintenance Guide 1.
Replace Magenta Develop.Unit soon	The printer is almost out of magenta development unit.	Prepare a new magenta development unit.

Messages/Second messages	Description	Solution
Replace PCU	It is time to replace the photoconductor unit.	Replace the photoconductor unit with a new one. See "Replacing Consumables and Maintenance Kit" in Maintenance Guide 1.
Replace Waste TonerBottle 1	It is time to replace waste toner bottle 1.	Replace waste toner bottle 1. See "Replacing Consumables and Maintenance Kit" in Maintenance Guide 1.
Replace Waste TonerBottle 2	It is time to replace waste toner bottles 2.	Replace the waste toner bottle 2 with a new one. See "Replacing Consumables and Maintenance Kit" in Maintenance Guide 1.
Replace Yellow Development Unit	It is time to replace the yellow development unit.	Replace the yellow development unit with a new one. See "Replacing Consumables and Maintenance Kit" in Maintenance Guide 1.
Replace Yellow Develop.Unit soon	The printer is almost out of yellow development unit.	Prepare a new yellow development unit.
Reset Charger Correctly	The charger is not installed correctly.	Contact your sales or service representative.
Reset Develop. Unit Correctly /Yellow/Magenta/Cyan/Black	The indicated development unit(s) is/are not set correctly or is not set.	Set the indicated development unit(s) correctly. See "Replacing Consumables and Maintenance Kit" in Maintenance Guide 1.
Reset Finisher Correctly	Finisher is not set correctly or is not set.	Set the Finisher correctly. See the Option Setup Guide.
Reset Fusing Unit Correctly	The fusing unit is not set correctly or is not set.	Set the fusing unit correctly. See "Replacing Consumables and Maintenance Kit" in Maintenance Guide 1.
Reset PCU Correctly	The photoconductor unit is not set correctly or is not set.	Set the photoconductor unit correctly. See "Replacing Consumables and Maintenance Kit" in Maintenance Guide 1.
Reset Toner /Yellow/Magenta/Cyan/Black	The indicated toner cartridge(s) is/are not set correctly.	Set the indicated toner cartridge correctly. See "Replacing Consumables and Maintenance Kit" in Maintenance Guide 1.

Messages/Second messages	Description	Solution
Reset Tray Correctly	The tray selected by the auto tray select is not set or is not set correctly.	Set the tray correctly. Or press [Form Feed] several times until the tray with desired paper setting appears on the panel display. Or press [Job Reset] to cancel the print job.
Reset Tray # Correctly	The indicated tray is not set or is not set correctly. #: tray number	Set the tray correctly. Or press [Form Feed] several times until the tray with desired paper setting appears on the panel display. Or press [Job Reset] to cancel the print job.
Reset Waste Toner1 Correctly	Waste toner bottle 1 is not set correctly or is not set.	Set waste toner bottle 1 correctly. See "Replacing Consumables and Maintenance Kit" in Maintenance Guide 1.
Reset Waste Toner2 Correctly	Waste toner bottle 2 is not set correctly or is not set.	Set waste toner bottle 2 correctly. See "Replacing Consumables and Maintenance Kit" in Maintenance Guide 1.
SC XXX-X Power Off On /If Error Reoccur Call Service	The Service Code or SC number indicates the problem.	Turn the power switch off and on. If the message appears again, contact your sales or service representative.
Setting Up... [>>>>]	The printer is internally setting up the consumables installed.	Wait for approximately 25 minutes until it is complete.
Toner is Almost Empty: Black	The black toner is almost empty.	Prepare a new black toner cartridge.
Toner is Almost Empty: Cyan	The cyan toner is almost empty.	Prepare a new cyan toner cartridge.
Toner is Almost Empty: Magenta	The magenta toner is almost empty.	Prepare a new magenta toner cartridge.
Toner is Almost Empty: Yellow	The yellow toner is almost empty.	Prepare a new yellow toner cartridge.
Waste Toner 1 is almost full	Waste toner bottles 1 is almost full of toner dust.	Prepare new waste toner bottle 1.
Waste Toner 2 is almost full	Waste toner bottles 2 is almost full of toner dust.	Prepare new waste toner bottle 2.

❖ Print Error Messages ("Error Log" in Configuration Page)

Messages/Second messages	Description	Solution
Collate Cancelled	The collate feature has been cancelled.	Install the optional Printer Hard Disk or increase the memory capacity to 128MB or more.
Driver Setting Error (Memory)	There is an error in the downloaded font(s).	Reset the parameter for downloading fonts.
Duplex Cancelled	Duplex printing has been canceled.	Confirm that the paper used is supported for duplex printing. Or, increase the memory capacity.
Exceeded Max. Pages (Collate)	The maximum number of pages has been exceeded for collation.	Install the optional Printer Hard Disk or increase the memory capacity to 128MB or more.
Exceeded Max. Stored Files	The maximum number of files has been exceeded during Sample Print or Locked Print.	Delete the stored files or reduce the file size of them.
Exceeded Max. Stored Pages	The maximum number of pages has been exceeded during Sample Print or Locked Print.	Reduce the number of pages to print.
HDD Full	The maximum hard disk area size for form/font has been exceeded.	Delete unused form/font types.
	An HDD overflow error occurred during Sample Print or Locked Print.	Delete the stored files or reduce the file size of them.
HDD Not Installed	The Sample Print or Locked Print feature was tried without the Printer Hard Disk installed.	To use the Sample Print or Locked Print feature, install the optional Printer Hard Disk. If the message appears again, contact your sales or service representative.
I/O Buffer Overflow	The maximum size of the I/O buffer has been exceeded.	Increase the size of the I/O buffer.
Memory Overflow	The printer identified a PostScript workarea overflow error.	Increase the memory capacity or decrease the file size to be downloaded.
Print Overrun	The image data has been thinned out due to image compression.	Increase the memory capacity.

Messages/Second messages	Description	Solution
RPCS Graphic Error	There is not enough graphics memory to print the data.	Specify the correct memory capacity in the [Change Accessories...] option in the RPCS printer driver's print settings tab. For more information, see the printer driver's Help.
		To print the image correctly, add memory to the printer, or reduce the resolution of the image.
RPCS Memory Overflow	A memory overflow occurred during the print job. After part of the data for the page was printed, the print job was suspended.	Specify the correct memory capacity in the [Change Accessories...] option in the RPCS printer driver's print settings tab. For more information, see the printer driver's Help.
		To print the image correctly, add memory to the printer, or reduce the resolution of the image.
RPCS Syntax Error	Bidirectional transmission may not be working properly or the RPCS printer driver settings may not be correct.	Confirm that the option settings for the printer driver match the options actually installed on the printer.
	There may not be enough memory or the memory settings for the printer driver may not match the memory actually installed on the printer.	Specify the correct memory capacity in the [Change Accessories...] option in the RPCS printer driver's print settings tab. For more information, see the printer driver's Help.
	This message may appear when the computer is connected to the printer with parallel interface.	To print the image correctly, add memory to the printer, or reduce the resolution of the image.
		Set the parallel interface mode of the computer to a mode other than ECP.

Printer Does Not Print

Possible Cause	Solutions
Is the power on?	Confirm that the cable is securely plugged into the power outlet and the printer. Turn on the power switch.
Does the On Line indicator stay on?	If not, press [On Line] to light it.
Does the Error indicator stay red?	If so, check the error message on the panel display and take the required action.
Is paper loaded?	Load paper into Tray 1 or on the Bypass Tray. See p.12 "Loading Paper".
Can you print a configuration page?	If you cannot print a configuration page, it probably indicates a printer malfunction. Contact your sales or service representative. See "Printing a Configuration Page" in the Administrator Reference.
Is the interface cable connected securely to the printer and the computer?	Connect the interface cable securely. If it has a fastener, fasten it securely as well.
Are you using the correct interface cable?	The type of interface cable you should use depends on the computer you use. Be sure to use the correct one. If the cable is damaged or worn, replace it with a new one. See "Appendix" in the Administrator Reference.





Possible Cause	Solutions
<p>Is the Data In indicator blinking or lit after starting the print job?</p>	<p>If not, the data is not being sent to the printer.</p> <ul style="list-style-type: none"> ❖ If the printer is connected to the computer using the interface cable Make sure the following printer port settings are correct: <ul style="list-style-type: none"> • For a parallel port connection, port LPT1 or LPT2 should be set. • For a USB port connection, port USB00 (n) *¹ should be set. • For a IEEE 1394 (SCSI print) port connection, port 1394_00(n) *¹ should be set. *¹ (n) is the number of printers connected. <ul style="list-style-type: none"> • Windows 95/98/Me <ol style="list-style-type: none"> ① Click [Start], point to [Settings] and then click [Printers]. ② Click to select the icon of the printer. Next, on the [File] menu, click [Properties]. ③ Click the [Details] tab. ④ Check the [Print to the following port] box to confirm that the correct port is selected. • Windows 2000 <ol style="list-style-type: none"> ① Click [Start], point to [Settings] and then click [Printers]. ② Click to select the icon of the printer. Next, on the [File] menu, click [Properties]. ③ Click the [Port] tab. ④ Check the [Print to the following port] box to confirm that the correct port is selected. • Windows XP <ol style="list-style-type: none"> ① Access the [Printers and Faxes] window from [Start] on the taskbar. ② Click to select the icon of the printer. Next, on the [File] menu, click [Properties]. ③ Click the [Port] tab. ④ Check the [Print to the following port(s).] box to confirm that the correct port is selected. • Windows NT 4.0 <ol style="list-style-type: none"> ① Click [Start], point to [Settings] and then click [Printers]. ② Click to select the icon of the printer. Next, on the [File] menu, click [Properties]. ③ Click the [Port] tab. ④ Check the [Print to the following port] box to confirm that the correct port is selected.

Possible Cause	Solutions
When you use 1394 Interface Unit Type4510	<p>❖ Network Connection</p> <p>Contact your network administrator.</p> <ol style="list-style-type: none"> ① Confirm that 1394 Interface Unit Type4510 is attached to the computer correctly. ② Confirm that IEEE1394 interface cable is connected securely. ③ Restart the computer. If the error occurs even after executing above operation, go to the following steps. ④ Unplug the IEEE1394 interface cable which is connected to the printer. ⑤ Execute the utility tool for 1394 Interface Unit Type4510 which is stored in the following path in the CD-ROM labeled "Printer Drivers and Utilities". <p>UTILITY\1394</p> <p> Important</p> <ul style="list-style-type: none"> ❑ For more information about using the utility tool for IEEE1394, see the README file in the same directory in the CD-ROM.

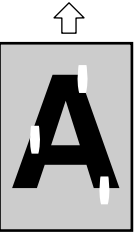
Other Printing Problems

2

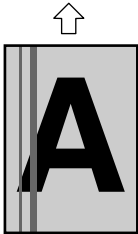
Status	Possible Causes, Descriptions, and Solutions
<p>Toner smears appear on the print side of the page.</p>	<p>When "Replace PCU" appears on the panel display, replace the photoconductor unit. See "Replacing Consumables and Maintenance Kit" in Maintenance Guide 1.</p> <p>Set the image density lighter with the control panel in the "Maintenance" menu. See "Cleaning and Adjusting the Printer" in Maintenance Guide 1.</p> <p>Confirm that the paper is not curled or bent. Envelopes can be curled easily. Flatten paper before loading. See p.7 "Paper Recommendations".</p>
<p>Toner smears appear on the back of the page when performing duplex printing.</p>	<p>Confirm that the paper type setting is made properly. When printing on the reverse side of thick paper between 120 to 130g/m² (32 to 35lb.Bond) that has been already printed on, select [Thick(Duplex Backside)] with the printer driver, and then select [>90g/m2, 24lb] with the control panel. See "Maintenance Menu" in the Administrator Reference.</p>
<p>Colors are missing.</p> 	<p>Confirm that the development unit is installed properly. See "Replacing Consumables and Maintenance Kit" in Maintenance Guide 1.</p>
<p>Colors are missing in some parts.</p> 	<p>Perform "Clean/ Adjust" with the control panel in the "Maintenance" menu. See "Cleaning and Adjusting the Internal Devices" in Maintenance Guide 1.</p>

Status	Possible Causes, Descriptions, and Solutions
<p>White or color streaks appear.</p> 	<p>Perform "Clean/Adjust" with the control panel in the "Maintenance" menu. See <i>"Cleaning and Adjusting the Internal Devices"</i> in Maintenance Guide 1.</p> <p>The photoconductor unit was exposed to a light. Remove the unit from the printer, and then place it in a dark room for a few hours. If this does not help, replace the unit. See <i>"Replacing Consumables and Maintenance Kit"</i> in Maintenance Guide 1.</p>
<p>White lines appear.</p> 	<p>Clean the dustproof glass. See <i>"Cleaning and Adjusting the Printer"</i> in Maintenance Guide 1.</p> <p>Perform "Clean/Adjust" with the control panel in the "Maintenance" menu. See <i>"Cleaning and Adjusting the Internal Devices"</i> in Maintenance Guide 1.</p> <p>Toner is almost empty. When "Add Toner" or "Toner is Almost Empty" appears on the panel display, replace the color of the toner cartridge. See <i>"Replacing Consumables and Maintenance Kit"</i> in Maintenance Guide 1.</p>
<p>Color lines appear.</p> 	<p>Perform "Clean/Adjust" with the control panel in the "Maintenance" menu. See <i>"Cleaning and Adjusting the Internal Devices"</i> in Maintenance Guide 1.</p>
<p>Color dots appear in 54 mm (2.1 inches) interval.</p> 	<p>Perform "Clean/Adjust" with the control panel in the "Maintenance" menu. See <i>"Cleaning and Adjusting the Internal Devices"</i> in Maintenance Guide 1.</p> <p>The photoconductor unit is deteriorated or damaged. Replace the unit. See <i>"Replacing Consumables and Maintenance Kit"</i> in Maintenance Guide 1.</p>

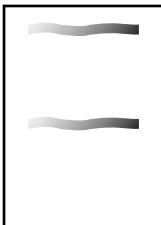
Status	Possible Causes, Descriptions, and Solutions
<p>The print on the entire page is faded out.</p> 	<p>Set the image density darker with the control panel in the "Maintenance" menu. See "Cleaning and Adjusting the Printer" in Maintenance Guide 1.</p> <p>Check [Toner Saving] under the [Print Quality] tab in the printer driver's dialog box to make prints lighter.</p> <p>Perform "Clean/ Adjust" with the control panel in the "Maintenance" menu. See "Cleaning and Adjusting the Internal Devices" in Maintenance Guide 1.</p> <p>Toner is almost empty. When "Add Toner" or "Toner is Almost Empty" appears on the panel display, replace the color of the toner cartridge. See "Replacing Consumables and Maintenance Kit" in Maintenance Guide 1.</p> <p>Paper used is not supported by the printer. See p.7 "Paper Recommendations".</p>
<p>Toner smears appear on the back of the page.</p> 	<p>You have canceled auto paper size/feed direction selection for Tray 1 or the Paper Feed Unit and set them manually with the control panel, and then load paper of different size or feed direction to the tray. In such a case, Reset the auto selection or load paper of the size and feed direction that have been set with the control panel. See p.12 "Loading Paper".</p> <p>The paper size and feed direction loaded on the Bypass Tray are different from them set with the control panel. Either change the setting or load paper to meet the setting. See p.23 "Loading Paper in the Bypass Tray".</p> <p>You printed data of larger paper size setting to a smaller size paper. The next print after making such print sometimes have smear on back of the page.</p> <p>Toner may be on the guide boards. Clean the guide boards. For more information, see "Cleaning the Registration Roller and the Guide Boards" in Maintenance Guide 1.</p> <p>Toner dust fell on inside of the printer when jammed paper was removed. Make a few prints until smears do not appear any more.</p>

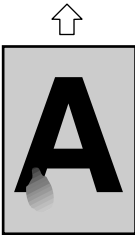
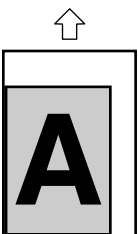
Status	Possible Causes, Descriptions, and Solutions
<p>Images are printed diagonally to the page.</p> 	<p>The paper guide in the paper tray is not locked. Lock the paper guide. See p.12 "Loading Paper".</p> <p>Paper in the paper tray is not loaded correctly. Load paper correctly. See p.12 "Loading Paper".</p> <p>The right cover of the printer or the Paper Feed Unit is not closed firmly. Close the cover firmly.</p>
<p>The print smudges.</p> 	<p>Thick paper is used but it is not set with the printer driver. Set it with the printer driver.</p> <p>Paper is damp. Use paper that has been stored properly. See p.7 "Paper Recommendations".</p> <p>Paper used is not supported by the printer. See p.7 "Paper Recommendations".</p> <p>The fusing unit is deteriorated or damaged. Replace the unit. See "Replacing Consumables and Maintenance Kit" in Maintenance Guide 1.</p>
<p>Images are not printed in the right position.</p> 	<p>Set the tray registration with the control panel in the "Maintenance" menu. See "Cleaning and Adjusting the Printer" in Maintenance Guide 1.</p>
<p>Paper gets wrinkles.</p>	<p>Paper is damp. Use paper that has been stored properly. See p.7 "Paper Recommendations".</p> <p>Paper is too thin. See p.1 "Paper Sizes".</p> <p>The fusing unit is deteriorated or damaged. Replace the unit. See "Replacing Consumables and Maintenance Kit" in Maintenance Guide 1.</p>

Status	Possible Causes, Descriptions, and Solutions
<p>"Reset Toner" appears on the panel display, and the printer does not print.</p>	<p>If this message appears after replacing the development units, the connectors are not securely connected to each development unit or the toner cartridges are not securely fit into place. See "Replacing Consumables and Maintenance Kit" in Maintenance Guide 1.</p>
	<p>If this message appears after the printer power is turned on, the toner cartridges are not securely fit into place. See "Replacing Consumables and Maintenance Kit" in Maintenance Guide 1.</p>
	<p>The toner cartridge of the indicated color is not set correctly or is not set. Set the color of the toner cartridge correctly. See "Replacing Consumables and Maintenance Kit" in Maintenance Guide 1.</p>
<p>The color of the printout is different from the color specified.</p>	<p>If a specific color is missing, turn the power switch off and on. If this does not solve the problem, contact your sales or service representative.</p>
<p>Color changes extremely when adjusted with the printer driver.</p>	<ul style="list-style-type: none"> • PCL 5c/Post Script Do not make extreme settings for the color balance in the [Advanced] dialog box under the [Print Quality] tab in the printer driver's dialog box. • RPCS Do not make extreme settings for the color balance in the [Image Adjustments] tab in the [Change User Settings] dialog box under the [Print Quality] tab in the printer driver's dialog box. The color sample does not show the color of the printout. See the printer driver's Help file.
<p>Photo images are coarse.</p>	<p>Some applications lower the resolution for making prints.</p>
<p>Black gradation is not natural.</p>	<ul style="list-style-type: none"> • PCL 5c/PostScript Select "CMY+K" for [Gray Reproduction] in the printer driver's [Advanced] dialog box under the [Print Quality] tab. • RPCS Select "CMY+K" for [Gray Reproduction] under the [Image Adjustments] tab in the printer driver's [Change User Setting] dialog box under the [Print Quality] tab.
<p>Color documents are printed in black and white.</p>	<p>The printer driver is not set up for color printing.</p> <ul style="list-style-type: none"> • PCL 5c/PostScript Select "Color" for [Color/Black and White] under the printer driver's [Setup] tab. • RPCS Select "Color" for [Color/Black and White] under the printer driver's [Print Settings] tab. See the printer driver's Help file.
	<p>Some applications print color files in black and white.</p>

Status	Possible Causes, Descriptions, and Solutions
Fine dot pattern does not print.	<ul style="list-style-type: none"> • PCL 5c/PostScript Change the [Dithering] setting in the Advanced dialog box under the printer driver's [Print Quality] tab. • RPCS Change the [Dithering] setting under the [Image Adjustments] tab in the [Change User Settings] dialog box under the [Print Quality] tab in the printer driver's dialog box. <p>See the printer driver's Help file.</p>
Images are cut off, or excess pages are printed.	<p>If you are using paper smaller than the paper size selected in the application, use the same size paper as that selected in the application. If you cannot load paper of the correct size, use the reduction function to reduce the image, and then print.</p> <p>See the printer driver's Help file.</p>
It takes too much time to complete the print job.	<p>Photographs and other data intensive pages take a long time for the printer to process, so simply wait when printing such data.</p> <p>Changing the following settings with the printer driver may help to speed up printing.</p> <ul style="list-style-type: none"> • PCL 5c Select "600 dpi", and then select "Fast" for [Gradation:] under the [Print Quality] tab in the printer driver's dialog box. • PostScript Select "Fast" for [Gradation] under the [Print Quality] tab in the printer driver's dialog box. Select "Post Script (optimize for speed)" for PostScript output format under the [PostScript] tab in the printer driver's dialog box. • RPCS Select "600×600 dpi" for [Resolution] under the [Image Adjustments] tab in the [Change User Settings] dialog box in the printer driver's dialog box. Select "Speed" for [Print priority] under [Print Quality] tab in the printer driver's dialog box. <p>See the printer driver's Help file.</p> <p>The data is so large or complex that it takes time to process it. If the Data In indicator is blinking, the data is being processed. Just wait until it resumes.</p> <p>If "Warming Up..." appears on the panel display, the printer is now warming up. Wait for a while.</p>

Status	Possible Causes, Descriptions, and Solutions
<p>It takes too much time to resume printing.</p>	<p>The data is so large or complex that it takes time to process it. If the Data In indicator is blinking, the data is being processed. Just wait until it resumes.</p>
	<p>The printer was in the Energy Saver mode. To resume from the Energy Saver mode, the printer has to warm up, and this takes time until printing starts. To disable the Energy Saver mode, select "Off" for "Energy Saver 1" in the System Settings menu.</p>
<p>Multiple pages are fed at once.</p>	<p>Number of paper set in the tray exceeds the limit. Confirm that the top of the stack is not higher than the limit mark inside the tray. See p.12 "Loading Paper".</p>
	<p>Paper is static. Use paper that has been stored properly. When loading paper, separate paper from each other. See p.7 "Paper Recommendations".</p>
	<p>Paper is either too thick or too thin. See p.1 "Paper Sizes".</p>
	<p>Paper has already been printed on. See p.7 "Paper Recommendations".</p>
	<p>The paper feed roller or the friction pad is not clean. Clean them. See "Cleaning and Adjusting the Printer" in Maintenance Guide 1.</p>
<p>Paper is not fed from the selected tray.</p>	<p>When using the Bypass Tray, confirm that the paper size and the feed direction on the tray are the same as the ones set with the control panel. See p.23 "Loading Paper in the Bypass Tray".</p>
	<p>When you are using a Windows operating system, the printer driver settings override those set using the control panel. Set the desired input tray using the printer driver. See the printer driver's Help file.</p>

Status	Possible Causes, Descriptions, and Solutions
Paper jams occur frequently.	The paper guide in the paper tray is not locked. Lock the paper guide. See p.12 "Loading Paper".
	The paper size and feed direction loaded on the Bypass Tray are different from them set with the control panel. Either change the setting or load paper to meet the setting. See p.23 "Loading Paper in the Bypass Tray".
	The end guide in the paper tray is not set correctly. Set the end guide correctly. See p.12 "Loading Paper".
	Number of paper set in the tray exceeds the limit. Confirm that the top of the stack is not higher than the limit mark inside the tray. See p.12 "Loading Paper".
	Paper is damp. Use paper that has been stored properly. See p.7 "Paper Recommendations".
	Paper is either too thick or too thin. See p.1 "Paper Sizes".
	Paper is bent or wrinkled. Use paper that have no bents or wrinkles. See p.7 "Paper Recommendations".
	Paper has already been printed on. See p.7 "Paper Recommendations".
	The paper feed roller or the friction pad is not clean. Clean them. See "Cleaning and Adjusting the Printer" in Maintenance Guide 1.
	The registration roller is not clean. Clean it. See "Cleaning and Adjusting the Printer" in Maintenance Guide 1.
	The fusing unit, paper feed roller or friction pad is deteriorated or damaged. Replace them. See "Replacing Consumables and Maintenance Kit" in Maintenance Guide 1.
Solid areas, lines or text are shiny or glossy when created as a mixture of cyan, magenta, yellow.	<p>Make the following settings with the printer driver.</p> <ul style="list-style-type: none"> • PCL 5c/PostScript Select "K(Black)" for [Gray Reproduction] in the printer driver's [Advanced] dialog box under the [Print Quality] tab. • RPCS Select "K(Black)" for [Gray Reproduction] under the [Image Adjustments] tab in the printer driver's [Change User Setting] dialog box.

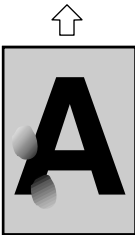
Status	Possible Causes, Descriptions, and Solutions
<p>Solid lines are printed as broken lines.</p>	<p>Make the following settings with the printer driver.</p> <ul style="list-style-type: none"> • PCL 5c/PostScript Change the [Dithering] setting in the [Advanced] dialog box under the printer driver's [Print Quality] tab. • RPCS Change the [Dithering] setting under the [Image Adjustments] tab in the [Change User Settings] dialog box, under the [Print Quality] tab in the printer driver's dialog box. <p>See the printer driver's Help file.</p>
<p>The print is partially faded out.</p> 	<p>Set the image density darker with the control panel in the "Maintenance" menu. See "Cleaning and Adjusting the Printer" in Maintenance Guide 1.</p> <p>Confirm that the printer is placed on a level surface.</p> <p>Toner is almost empty. When "Add Toner" or "Toner is Almost Empty" appears on the panel display, replace the color of the toner cartridge. See "Replacing Consumables and Maintenance Kit" in Maintenance Guide 1.</p> <p>Paper is damp. Use paper that has been stored properly. See p.7 "Paper Recommendations".</p> <p>Paper used is not supported by the printer. See p.7 "Paper Recommendations".</p> <p>The toner cartridge or the photoconductor unit is not set correctly. See "Replacing Consumables and Maintenance Kit" in Maintenance Guide 1.</p> <p>The photoconductor unit is deteriorated or damaged. Replace the unit. See "Replacing Consumables and Maintenance Kit" in Maintenance Guide 1.</p>
<p>The color of the printout is different from the color on the computer's display.</p>	<p>The colors made using color toner are different from colors displayed on the display in its production system. See "Appendix" in the Client Reference.</p> <p>When [Toner Saving] is checked under the [Print Quality] tab in the printer driver's dialog box, the color gradation may appear differently. See the printer driver's Help file.</p>
<p>Images are printed in the wrong orientation.</p>	<p>The feed direction you selected and the feed direction selected in Option Setup of the printer driver might not be the same. Make the proper settings.</p>
<p>An error message on the control panel stays on after removing the misfed paper.</p>	<p>Open the front cover of the printer, and then close it.</p>

Status	Possible Causes, Descriptions, and Solutions
A print image is not clear.	Due to a sudden change in temperature, condensation might appear inside the printer, reducing print quality. If this occurs when you move the printer from a cold room to a warmer room, do not use the printer until it acclimatizes to the temperature.
The print side of the page is a hazy gray.	Adjust the image density. To adjust the image density, press [Menu] , and select Image Density from the "Maintenance" menu. See " <i>Adjusting the Image Density</i> " in Maintenance Guide 1.
	If paper is curled, flatten it. Curled or folded paper might cause a hazy gray print. Curling often occurs on envelopes, so be sure to flatten it before printing.
A printed image is different from the image on the computer's display.	When you use some functions, such as enlargement and reduction, the layout of the image might be different from that displayed in the computer display.
	You might have selected to replace True Type fonts with printer fonts in the printing process. To print an image similar to the image on the computer, make the settings to print out True Type fonts as an image. See the printer driver's Help file.
The printer does not print at 1800dpi, even if 1800dpi resolution is selected.	Printing at 1800dpi uses much memory. Therefore, depending on the memory capacity, you may not be able to print at 1800dpi. Either add memory to the printer or reduce the size of data to be printed is required. See " <i>Memory Capacity and Paper Size</i> " in the Administrator Reference.

 **Note**

- If the problem cannot be solved, contact your sales or service representative.

Removing Misfed Paper

When a paper misfeed occurs, an error message appears on the panel display. Remove the misfed paper from the location indicated.

2

Important

- ❑ Toner dust may be on the misfed paper after removal. Be careful not to get it on your hands or clothes.
- ❑ Toner dust may be on the paper printed after removing misfed paper. Make a few prints until smears do not appear any more.

When "Remove Misfed A: Internal Path" Appears

1 Open the Bypass Tray.

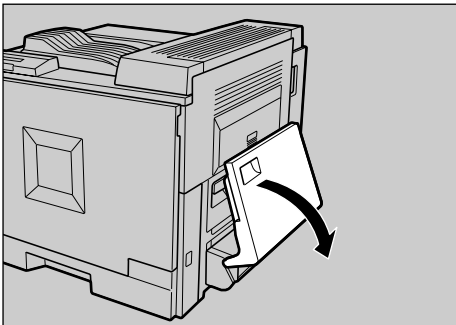

ZESH206J

Note

- ❑ Remove the paper on the Bypass Tray to prevent them from falling.

2 If the Duplex Unit is installed, open it by pushing the catch upwards.

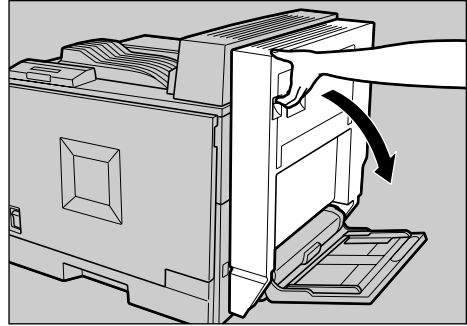

ZESH510J

3 Open the right cover of the printer by pushing up the handle.

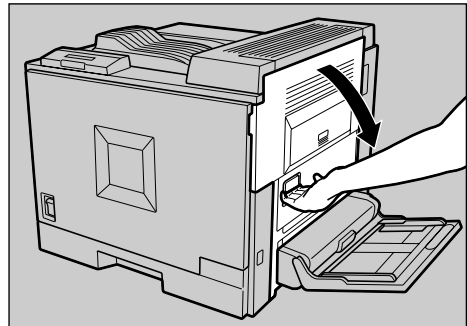

ZESH458J

4 Remove the misfed paper.

- ❖ **When the Misfed Paper is Visible**
Hold the misfed paper and remove it while turning the blue dial shown in the illustration slowly in clockwise and counterclockwise directions.

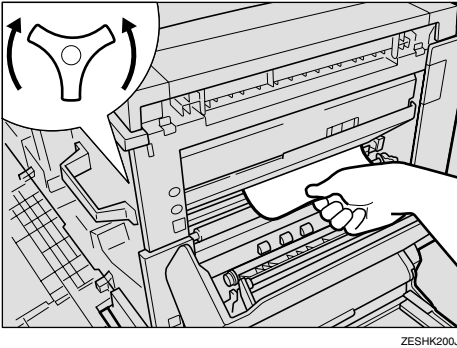

- ❖ **When the Misfed Paper is not Visible**

- ① Turn the blue dial shown in the illustration slowly in a clockwise direction.

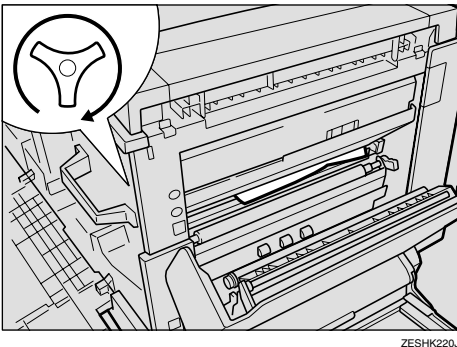

- ② The misfed paper comes out. If the paper is not visible, search for the paper by peering into the printer from its right side where the cover is open.
- ③ Remove the paper by the same procedure as described in "When the Misfed Paper is Visible".

- ❖ **When the Misfed Paper Cannot be Removed**

Contact your sales or service representative.

5 Close the right cover of the printer.

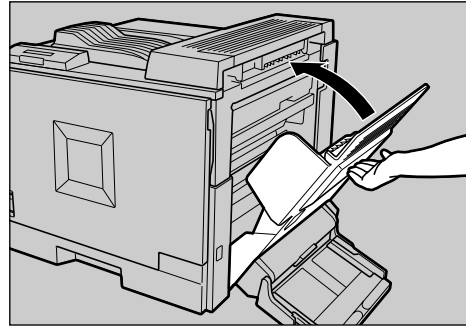

Note

- Press "PUSH" to close the cover firmly.

6 If you cannot see the misfed paper by opening the right cover, open the paper tray of the Paper Feed Unit to remove the misfed paper.

7 If the Duplex Unit is installed, close it.

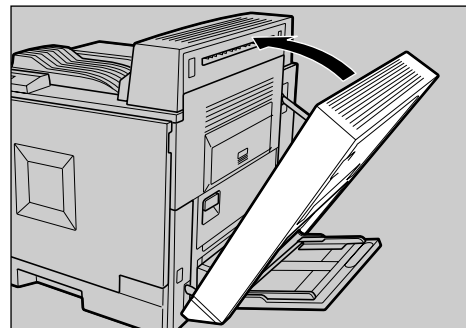

8 Close the Bypass Tray.

When "Remove Misfed B: Fusing Unit" Appears

⚠ CAUTION:

- The inside of the machine becomes very hot. Do not touch the parts with a label indicating "⚠" (means hot surface). Touching "⚠" (means hot surface) could result in a burn.

- 1** Open the front cover slowly by pulling down from the two areas on the left and right.

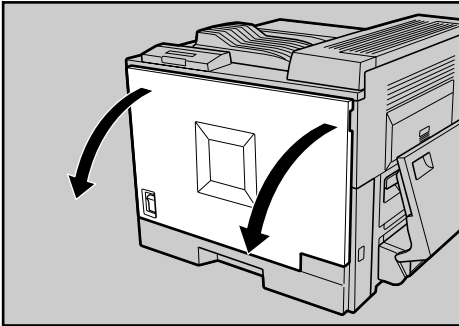

ZESH400J

- 2** Open the Bypass Tray.

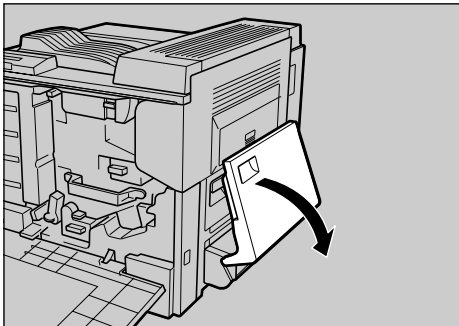

ZESH047J

Note

- Remove the paper on the Bypass Tray to prevent them from falling.

- 3** If the Duplex Unit is installed, open it by pushing the catch upwards.

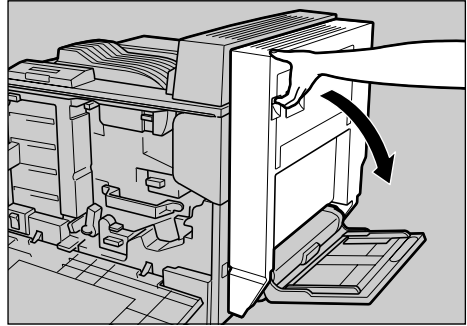

ZESH048J

- 4** Open the right cover of the printer by pushing up the handle.

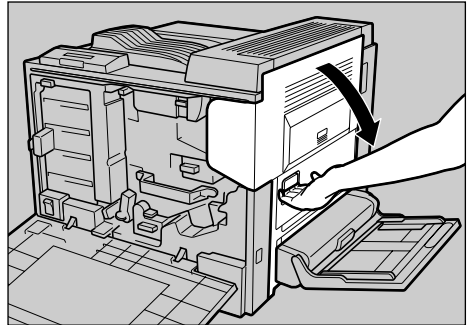

ZESH208J

- 5** Open the upper right cover of the printer.

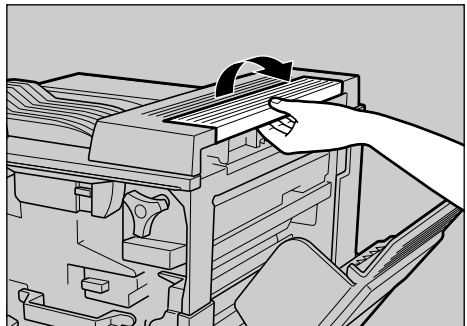

ZESH511J

Note

- When the Interchange Unit is installed, see p.59 "Removing Misfed Paper from the Interchange Unit".

6 Remove the misfed paper.

- ❖ **When the Misfed Paper is Visible**
Hold the misfed paper and remove it while turning the blue dial shown in the illustration slowly in clockwise and counterclockwise directions.

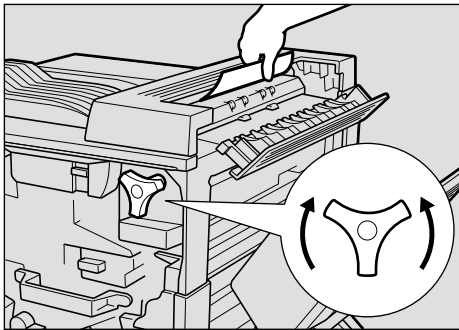

ZESYK210J

- ❖ **When the Misfed Paper is not Visible**

- ① Turn the blue dial shown in the illustration slowly in a clockwise direction.

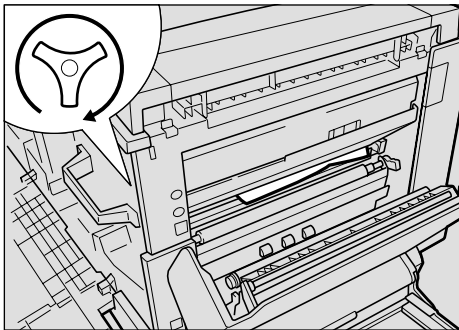

ZESHK220J

- ② The misfed paper comes out. If the paper is not visible, search for the paper by peering into the printer from its right side where the cover is open.
- ③ Remove the paper by the same procedure as described in "When the Misfed Paper is Visible".

- ❖ **When the Misfed Paper Cannot be Removed**

Contact your sales or service representative.

7 Close the upper right cover of the printer.

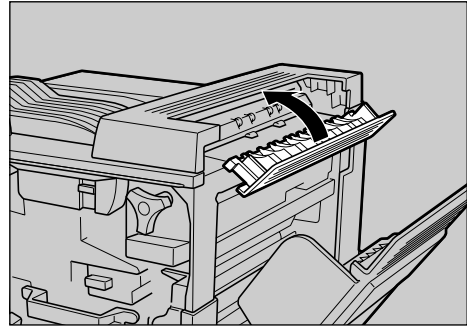

ZESH513J

2

8 Close the right cover of the printer.

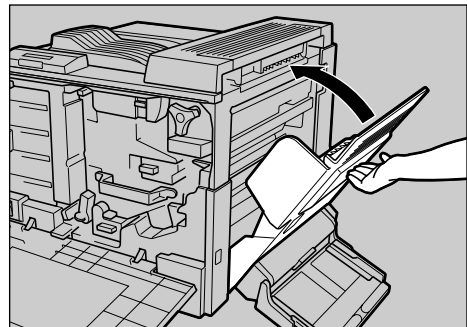

ZESH010J

Note

- ☐ Press "PUSH" to close the cover firmly.

- 9** If the Duplex Unit is installed, close it.

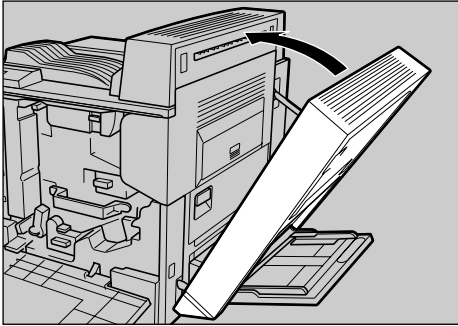

- 10** Close the Bypass Tray.

- 11** Close the front cover slowly by pushing the two areas on the left and right.

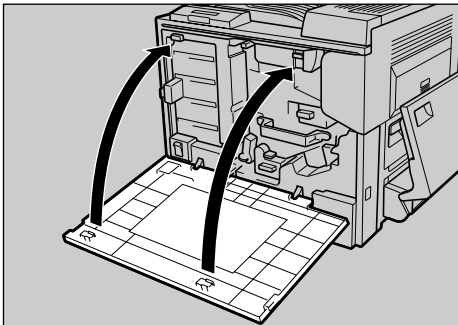

When "Remove Misfeed R: Finisher" Appears

- 1** Open the right cover of the Finisher (①), and slowly pull out the misfed paper (②).

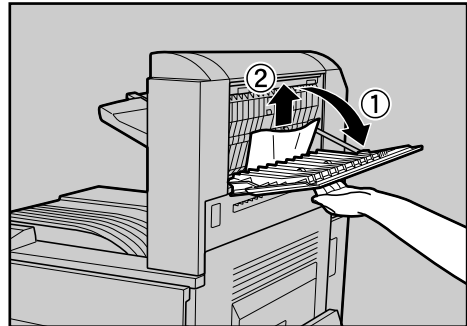

- 2** Slowly close the right cover of the Finisher.

- 3** If you can see the misfed paper on its output tray, open the upper cover (①) and slowly remove the misfed paper (②).

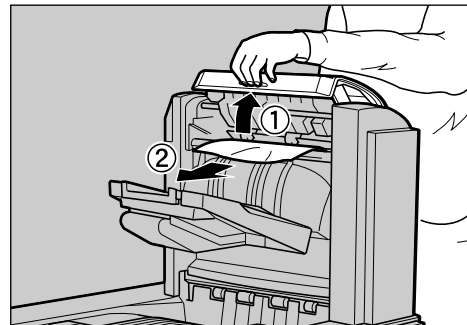

- 4** If you still cannot remove the misfed paper, see inside the Interchange Unit. See p.59 "Removing Misfed Paper from the Interchange Unit".

When "Remove Misfeed Y: Paper Tray" Appears

- 1 Open the right cover of the Paper Feed Unit (①), and slowly pull out the misfed paper (②).

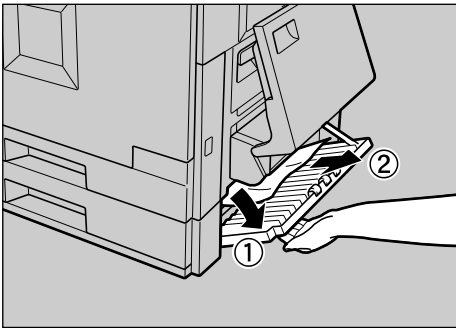

ZESY209J

Note

- When two Paper Feed Units are installed, follow the same procedure for both of them.

- 2 If you cannot see the misfed paper by opening the right cover, open the paper tray of the Paper Feed Unit to remove the misfed paper.
- 3 Close the right cover of the Paper Feed Unit.

When "Remove Misfeed Z: Duplex Unit" Appears

⚠ CAUTION:

- The inside of the machine becomes very hot. Do not touch the parts with a label indicating "⚠" (means hot surface). Touching "⚠" (means hot surface) could result in a burn.

- 1 Open the right cover of the Duplex Unit (①), and slowly pull out the misfed paper (②).

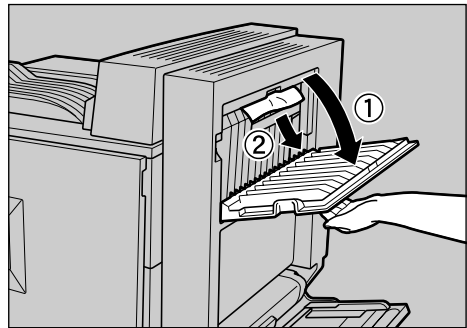

ZESY210J

If you cannot remove the misfed paper, do not remove it with force, but go to the next step.

- 2 Close the right cover of the Duplex Unit.
- 3 Open the Duplex Unit by pushing the catch upwards.

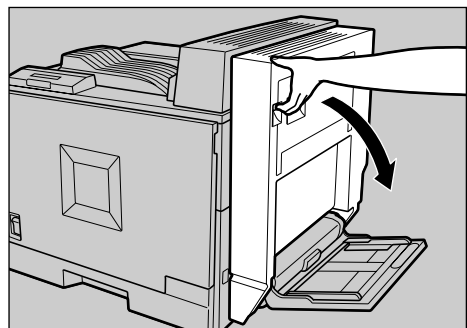

ZESH510J

- 4** Open the panel (①), and slowly pull out the misfed paper (②).

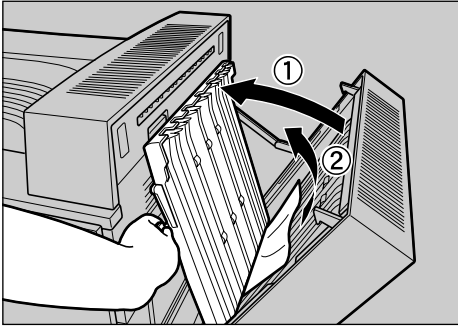

ZESV212J

- 5** Close the panel.
- 6** If you still cannot remove the misfed paper, see inside the Interchange Unit. See p.59 "Removing Misfed Paper from the Interchange Unit".
- 7** Close the Duplex Unit.

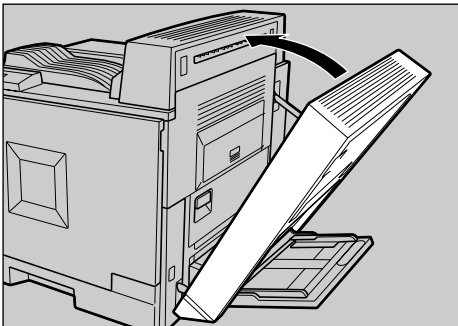

ZESH460J

- 8** Close the Bypass Tray.

When "Remove Misfeed W: Mailbox" Appears

- 1** Open the 4-bin Mailbox cover (①), and slowly pull out the misfed paper (②).

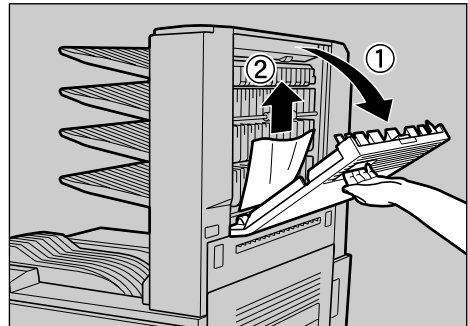

ZESV207J

- 2** Close the 4-bin Mailbox cover.
- 3** If you still cannot remove the misfed paper, see inside the Interchange Unit. See p.59 "Removing Misfed Paper from the Interchange Unit".

Removing Misfed Paper from the Interchange Unit

⚠ CAUTION:

- The inside of the machine becomes very hot. Do not touch the parts with a label indicating "⚠" (means hot surface). Touching "⚠" (means hot surface) could result in a burn.

- 1** Open the front cover slowly by pulling down from the two areas on the left and right.

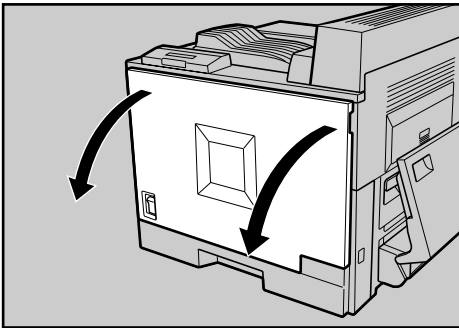

ZESY214J

- 2** Open the right cover of the printer by pushing up the handle.

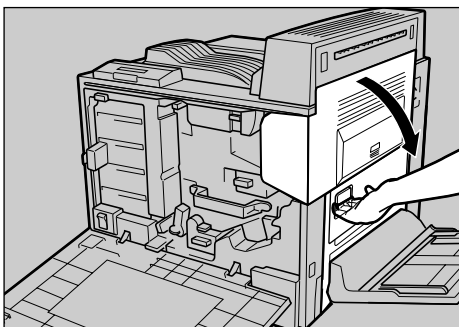

ZESY220J

- 3** Open the right cover of the Interchange Unit.

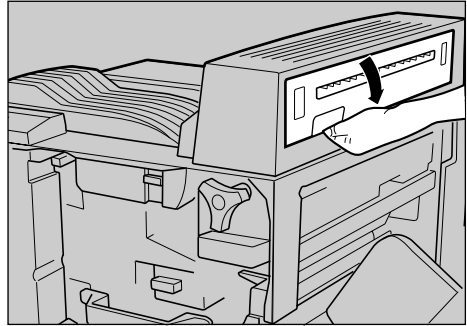

ZESY215J

- 4** If you can see the misfed paper, slowly pull it out.

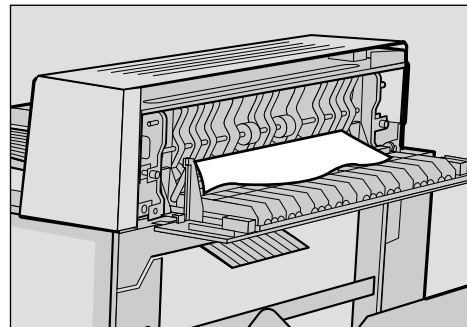

ZESY216J

If you cannot remove the paper easily, do not pull it with force, but go to the next step.

- 5** Turn the blue dial shown in the illustration counter-clockwise, and slowly remove the misfed paper.

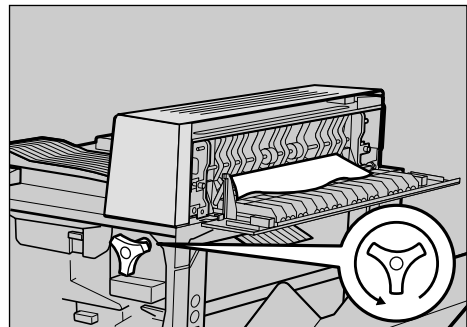

ZESY217J

Important

- Be sure to turn the dial counter-clockwise. Turning it to the other direction sends the paper into the interior of the printer and makes it more difficult to remove it.

2

- 6** Close the right cover of the Interchange Unit.

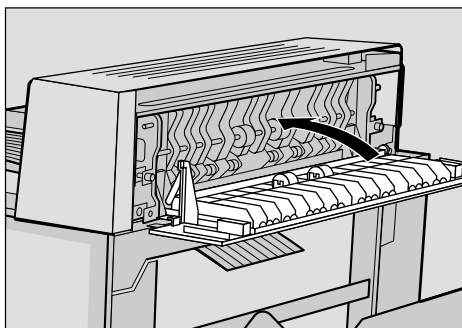

ZESY218J

- 7** Close the right cover of the printer.

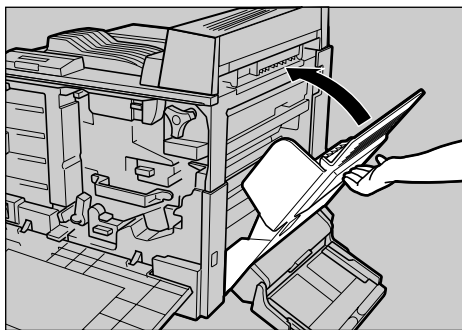

ZESY221J

Note

- Press "PUSH" to close the cover firmly.

- 8** Close the front cover slowly by pushing the two areas on the left and right.

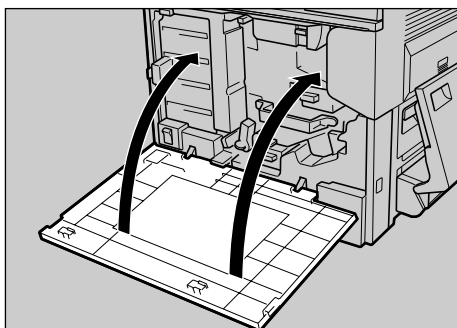

ZESY219J

Removing Jammed Staples

When "Add Staples" appears on the panel display, or when the printer does not staple even after it is instructed to, the staples might be jammed.



- 1** Open the rear cover of the Finisher.

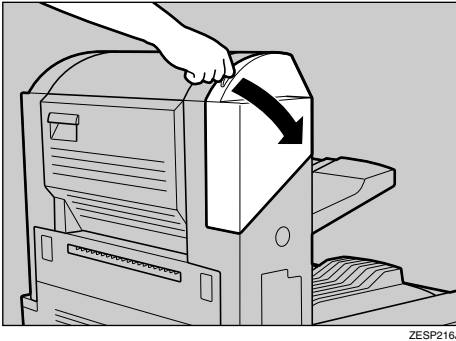

ZESP216J

- 2** Remove the cartridge by pulling the green knob in the direction of the arrow.

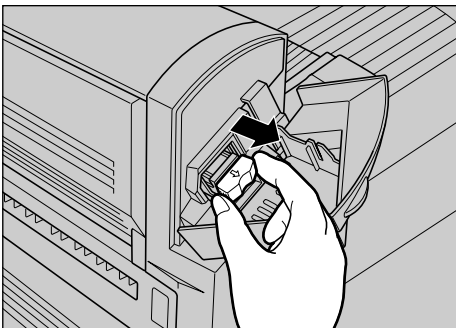

ZESP217J

- 3** Open the face plate (①) of the cartridge to unlock it.

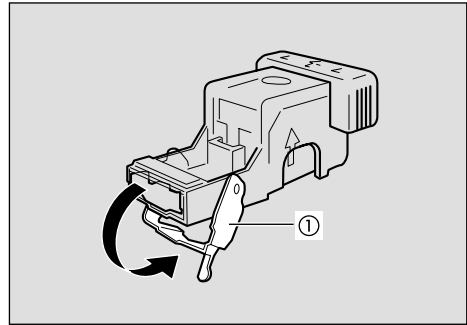

ZESP227E

- 4** Remove the jammed staples.

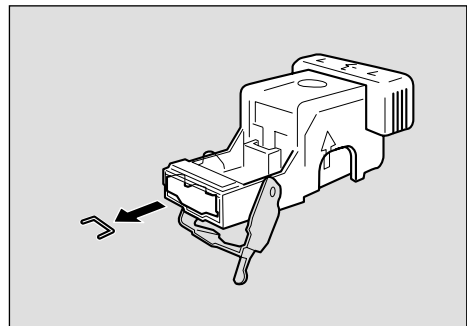

ZESP228J

- 5** Close the face plate of the cartridge until it clicks into place.

- 6** Insert the cartridge until it clicks into place.

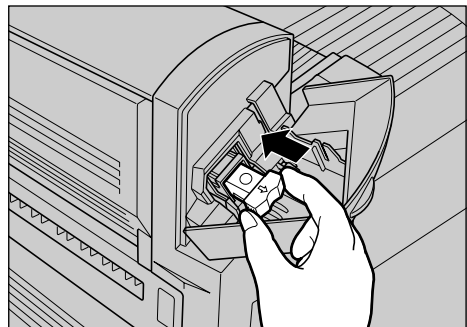

ZESP218J

- 7** Close the rear cover of the Finisher.

2

Adding Staples

When "Add Staples" appears on the panel display, add a new staple refill.



2

1 Open the rear cover of the Finisher.

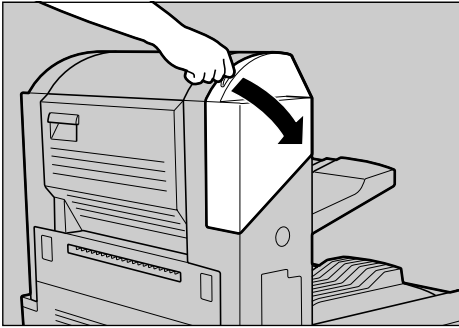

ZESP216J

2 Remove the cartridge by pulling the green knob in the direction of the arrow.

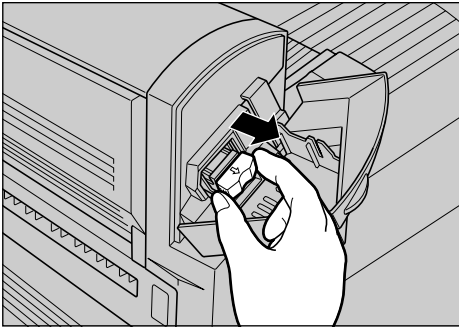

ZESP217J

3 Remove the empty refill as shown in the illustration.

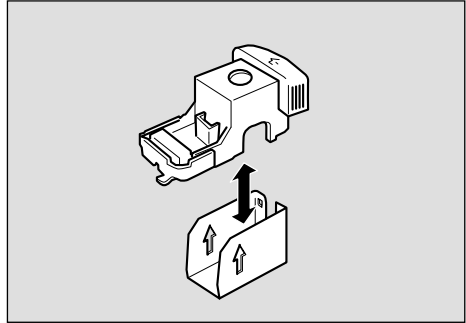

ZESP222J

4 Set the new refill to the cartridge until it clicks into place.

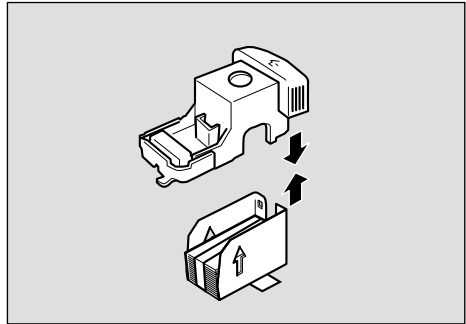

ZESP224J

 **Note**

- Do not remove the tape that is binding the staples until the refill is set in the cartridge.

5 Remove the tape that is binding the staples.

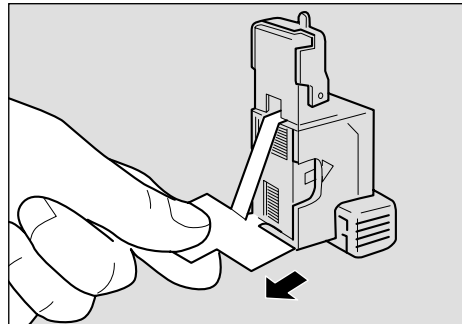

ZESP225J

- 6** Set the cartridge until it clicks into place.

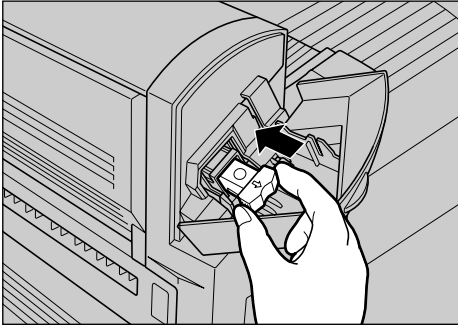

ZESP218J

- 7** Close the rear cover of the Finisher.

INDEX

A

Adding Staples, 62

B

Bypass Tray
 Custom Size, 24
 Paper Type, 25

C

Changing paper size
 Tray, 13, 18

D

Data In indicator, 40, 47, 48
Display panel, messages, 27

E

Envelopes, 9
Error, 27
Error indicator, 39

I

Input Paper Sizes, 1

L

Loading Paper, 7, 12
 Bypass Tray, 23
 Optional Paper Feed Unit, 18
 paper size, 14, 20
 paper type, 17, 22
 Tray 1, 12

M

messages, 27

O

OHP transparencies, 9
Online indicator, 39
Online key, 39
Other Printing Problems, 42
Output Paper Sizes, 4

P

Paper and Other Media, 1
Paper not supported by this printer, 10
Paper Recommendations, 7
Paper Size, 1
Paper weight and number of sheets to be set, 4
Plain Paper, 7
Printable Area, 11
Printer Does Not Print, 39

R

Remove Misfed Paper
 Duplex Unit, 57
 Finisher, 56
 Fusing Unit, 54
 Interchange Unit, 59
 Internal Path, 52
 Mailbox, 58
 Paper Tray, 57
Removing Jammed Staples, 61
Removing Misfed Paper, 52

S

Storing Paper, 7

T

Thick Paper, 8
Troubleshooting, 27

